



04-2025 Ver. 17476/9

PAC 511 DCi One-Door Controller

Installation Guide

PAC 511 DCi Unità di Controllo

Manuale di Installazione

PAC 511 DCi Styrenhet för access

Snabbstart

PAC 511 DCi Zutritts-Controller

Kurzanleitung

PAC 511 DCi Toegangscontroller

Snelstartgids

PAC 511 DCi Contrôleur d'accès

Guide d'initiation rapide

PAC 511 DCi Styreenhet for adgang

Hurtigguide

PAC 511 DCi Controlador de acceso

Guía de inicio rápido

PAC 511 DCi 门控制器

快速启动指南

Technical Support • Supporto tecnico • Technischer Support • Service technique • Asistencia técnica • Teknisk support • Technische ondersteuning • Teknisk support • 技术支持

pacgdxsupport@comelit-pac.co.uk

T: +44 (0)1707 377203

Customer Services • Servizio Clienti • Kundendienst Service clients • Servicio de atención al cliente • Kundtjänst • Klientenservice • Kundeservice • 客户服务

pacgdxcustomerservice@comelit-pac.co.uk

T: +44 (0)1707 377203

Training • Corsi Tecnici • Schulung • Formation • Formación Utbildning • Training • Opplæring • 培训

trainingacademy@comelit-pac.co.uk

T: +44 (0)1707 377203

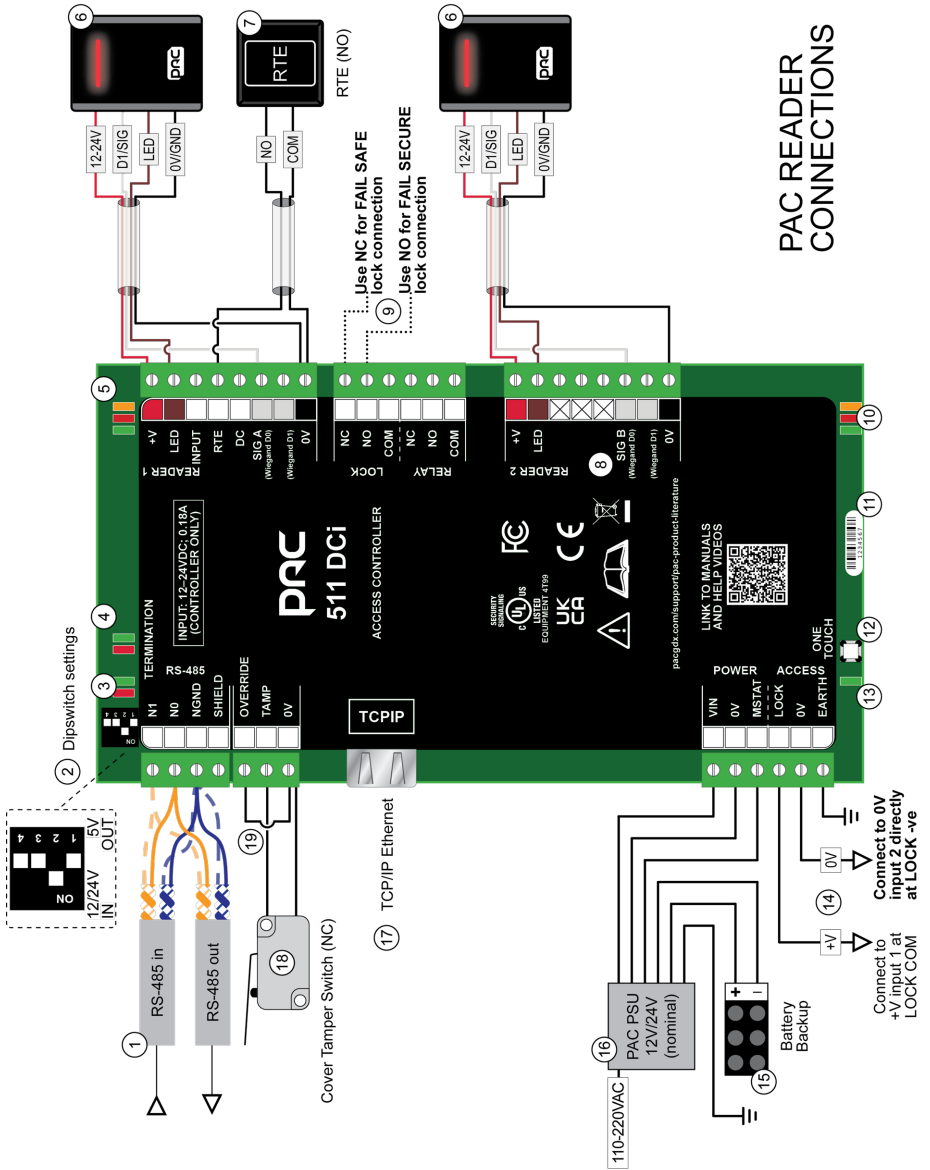

Lock wiring options

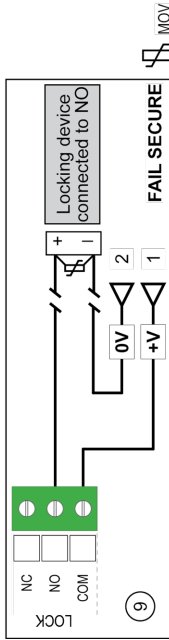
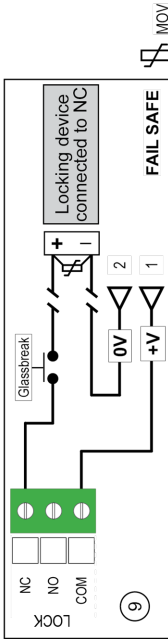

Electrical Ratings

Input Ratings	Input Voltage	Input Current	Hz
Power, Controller (VIN, 0V)	10.5-28 VDC	180 mA	-

Output Ratings	Output VDC	Output current A	Notes
Access (Lock, 0V)	27.6	1.5 (1.8 max)	When powered by (1)
Access (Lock, 0V)	13.8	3 (3.3 max)	When powered by (2)
Access (Lock, 0V)	27.6	3	When powered by (3)
Access (Lock, 0V)	13.8	6	When powered by (3)
Door1, Door2 (+V,0V)	13.8 or 27.6	0.3	When powered by (1), (2), (3)

Lock1, Relay1	Dry relay contacts rated 30 VDC, 5A
---------------	-------------------------------------

Notes:

- (1) PSU 50W 24V nominal
- (2) PSU 50W 12V nominal
- (3) PSU 99W 24V nominal

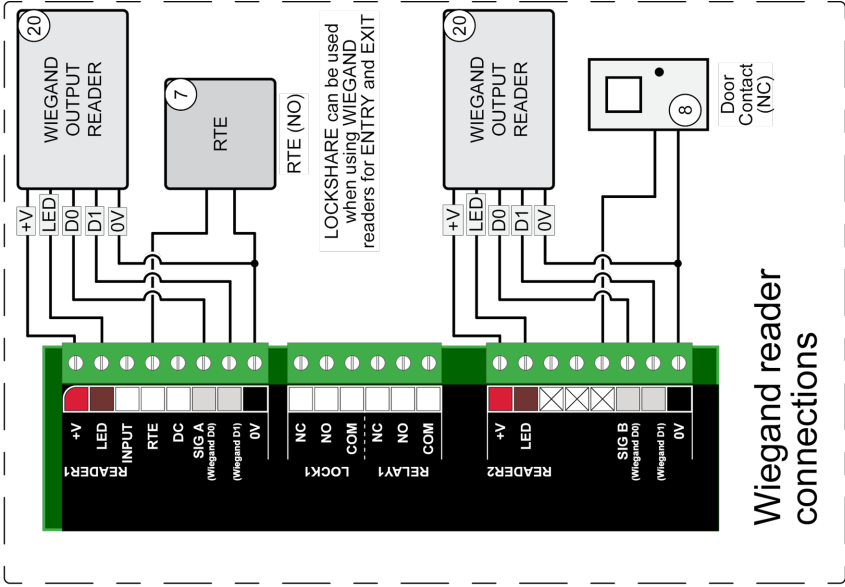

LOCKSHARE can be used when using WIEGAND readers for ENTRY and EXIT

MOV

MOV

Introduction

This document is intended for experienced engineers who are familiar with PAC products and health and safety considerations.

Additional information on software installation and operation is given in the documentation and help files provided with the administration software.

 **All similar controllers on the system should have the same firmware version number.**

A firmware download to the new controller may be required, see the help file for further details.

Tamper and Override Terminal (NC)

Before powering up, use a short piece of cable to link:

- tamper (TAMP) and 0V terminals.
- override (OVERRIDE) and 0V terminals.

Override can be configured for EOL operation if required.

RS-485 Connection

When shielded cables are used, connect the shield on one controller to the earth terminal labelled "SHIELD".

 **Only the first and last controllers in the chain, must have the RS-485 dipswitch set to "IN".**

RS-485 LED	Description
RED	The controller is transmitting data
GREEN	Another controller is transmitting data on the network

Lock EMF Suppression

All locks must be fitted with a means of suppressing back EMF ('spikes'), which are generated by most electric releases, especially magnetic locks.

All readers and controllers supplied by PAC are supplied with a Metal Oxide Varistor (MOV).

For currents >1A use the large MOV supplied with the **controller**.

For currents <1A use the small MOV supplied with the **reader**.

The MOV will prevent the controller from suffering long term damage.

Whenever possible this device should be fitted across the lock terminals. If for any reason the lock terminals are inaccessible, the MOV may be fitted across the lock output.

The lock relays are protected by a 3A circuit breaker in line with the **RELAY COM** connection. These will automatically be reset when the overload has been removed; both lock outputs are independent.

















Legend for Wiring Diagram on page 2-3

1	RS-485 connection														
2	Dipswitch settings <ol style="list-style-type: none"> 1. RS-485 termination (IN <u>or</u> OUT, default = OUT) 2. Reader voltage selector (12/24V <u>or</u> 5V, default = 12/24V) 3. N/A 4. N/A 														
3	RS485 status LEDs														
4	RS-232 status LEDs														
5	Door 1 LEDs														
6	Reader <table style="margin-left: 20px; border: none;"> <tr><td>+V</td><td>Red</td></tr> <tr><td>SIGA/SIGB</td><td>White</td></tr> <tr><td>LED</td><td>Brown</td></tr> <tr><td>0V</td><td>Black</td></tr> <tr><td>0V (sonder)</td><td>Yellow</td></tr> <tr><td>0V (tamper/DC - door contact)</td><td>Blue</td></tr> </table>	+V	Red	SIGA/SIGB	White	LED	Brown	0V	Black	0V (sonder)	Yellow	0V (tamper/DC - door contact)	Blue		
+V	Red														
SIGA/SIGB	White														
LED	Brown														
0V	Black														
0V (sonder)	Yellow														
0V (tamper/DC - door contact)	Blue														
7	Request to Exit (NO) <table style="margin-left: 20px; border: none;"> <tr><td>RTE</td><td>Blue</td></tr> <tr><td>0V</td><td>Black</td></tr> </table>	RTE	Blue	0V	Black										
RTE	Blue														
0V	Black														
8	Door Contact														
9	Lock wiring options: <ul style="list-style-type: none"> • FAIL SAFE—connect to NC • FAIL SECURE—connect to NO 														
10	—														
11	Serial Number and Barcode														
12	One-Touch™ button														
13	System status LED														
14	Power Access														
15	Battery Backup														
16	12V/24V nominal Power Supply Unit <table style="margin-left: 20px; border: none;"> <tr><td colspan="2" style="text-align: right;">PAC ONLY **</td></tr> <tr><td>VIN</td><td>Orange</td></tr> <tr><td>0V</td><td>White</td></tr> <tr><td>MSTAT</td><td>Pink</td></tr> <tr><td>(Battery) +</td><td>Red</td></tr> <tr><td>(Battery) -</td><td>Black</td></tr> <tr><td>EARTH</td><td>Green/Yellow</td></tr> </table>	PAC ONLY **		VIN	Orange	0V	White	MSTAT	Pink	(Battery) +	Red	(Battery) -	Black	EARTH	Green/Yellow
PAC ONLY **															
VIN	Orange														
0V	White														
MSTAT	Pink														
(Battery) +	Red														
(Battery) -	Black														
EARTH	Green/Yellow														
17	PC RS-232 or Ethernet connection														
18	Cover Tamper Switch (NC)														
19	Door Override (NC) <ul style="list-style-type: none"> • Removal of short will operate lock relay • NOT rated for use as a FIRE OVERRIDE 														
20	Wiegand Reader														

** Refer to manufacturer's guide for 3rd-party PSU

One Touch™ Test Mode

To speed up installation and testing, One-Touch™ testing is provided which allows the controller functionality to be tested at the controller or reader.

Test	Action	Observation			
		Controller	Reader		
Normal Operation		 Green	System status: GREEN flashes at normal rate.		
		 Green-Red-Yellow	Door status: All LEDs off.		
One-Touch™ View Mode	Hold down One-Touch™ button for less than 2 seconds. Present keys, press RTE switches and observe LEDs. Automatically exits after 2 minutes.	 Green	System status GREEN flashes at normal rate.		
		 Green-Red-Yellow	Door status: GREEN on, valid key presented to reader.		
		 Green-Red-Yellow	Door status: GREEN flashes, invalid key presented to reader.		
		 Green-Red-Yellow	Door status: RED on, door open.		
		 Green-Red-Yellow	Door status: YELLOW on, RTE switch has been pressed.		
One-Touch™ Active Mode	Hold down One-Touch™ button for 2 to 4 seconds.	 Green	System status: GREEN flashes faster than normal.	 Green	Normal operation of the reader LED changes, e.g. if default is red it changes to green.
Reader and Request to Exit Test	Present a key to each reader (the lock will activate).	 Green-Red-Yellow	Door status: GREEN flashes once for SIGA, twice for SIGB.	 Red	Reader LED flashes once for SIGA, twice for SIGB.
	Press the Request to Exit switch (the lock will activate).	 Green-Red-Yellow	Door status: GREEN flashes three times and YELLOW is on.	 Red	Reader LED flashes three times.
	Open the door contact.	 Green-Red-Yellow	Door status: GREEN flashes four times and RED is on.	 Red	Reader LED flashes four times.
Auxiliary and Lock Relays Test	Present a key to a reader, press the Request to Exit switch and open the door contact simultaneously.		The appropriate auxiliary relay is activated.		
	Remove link to 0V on tamper or open circuit tamper switch.		Both auxiliary relays are activated.		
	Remove link to 0V on emergency override or leave open circuit tamper switch.		The auxiliary relay is activated.		
Tamper and Override Test	Remove the link between TAMP and 0V on the Tamper & Override terminal block.		The auxiliary relay is activated but the door relays are unaffected.		
	Remove the link between OVRD and 0V on the Tamper & Override terminal block.		Both auxiliary and lock relays are activated, the door opens and the lock operates.		
Leave One-Touch™ Active Test mode	Hold down One-Touch™ button for less than 2 seconds. One-Touch™ Test mode will automatically be timed out after 1 hour, power up or power down.	 Green	System status: GREEN flashes at normal rate again.	 Red	Reader LED returns to normal operation.

Introduzione

Questo documento è destinato a tecnici esperti che hanno familiarità con i prodotti PAC. Verificare sempre di poter lavorare in sicurezza.

Ulteriori informazioni sull'installazione e sul funzionamento sono contenute nella documentazione e nei file di aiuto forniti con il software di amministrazione.

NB. Tutti gli stessi controllori del sistema devono avere la stessa versione firmware.

Verificare l'ultima versione firmware direttamente sul sito. Per ulteriori dettagli, consultare il file di guida.

Ingressi Tamper and Override/Emergenza (NC)

Prima di alimentare l'Unità di Controllo ponticellare:

- Terminale tamper (TAMP) e 0V.
- Terminale Override/Emergenza (OVERRIDE) e 0V.

Se richiesto il terminale OVERRIDE può essere gestito con EOL.

Collegamento RS-485

Se viene utilizzato un cavo schermato, collegare lo schermo al terminale "SHIELD".

! Solo la prima e l'ultima Unità di Controllo devono avere il dipswitch RS485 programmato "IN".

RS-485 LED	Descrizione
ROSSO	Unità di Controllo sta trasmettendo
VERDE	Un'altra Unità di Controllo sta trasmettendo

Serrature Soppressione EMF

Le serrature devono essere dotate di un varistore per sopprimere i campi elettromagnetici di ritorno ("spikes"), generati dalla maggior parte delle serrature elettriche, in particolare quelle magnetiche.

Tutti i lettori e i controllori forniti da PAC sono dotati di un varistore all'ossido di metallo (MOV).

Per correnti >1A utilizzare il MOV grande fornito con l'**Unità di Controllo**.

Per correnti <1A utilizzare il MOV piccolo fornito con il **lettore**.

Il MOV impedisce al controllore di subire danni a lungo termine.

Se possibile, il MOV deve essere montato direttamente sull'uscita della serratura.























I relè della serratura sono protetti da un fusibile elettronico da 3A in linea con il collegamento **RELAY COM**, che si ripristina automaticamente una volta rimosso il sovraccarico; entrambe le uscite di blocco sono indipendenti.

1	Collegamento RS 485												
2	Programmazione Dipswitch <ol style="list-style-type: none"> 1. RS-485 terminazione (IN o OUT, default = OUT) 2. Selezione Alimentazione Lettore (12/24V o 5V, default = 12/24V) 3. N/A 4. N/A 												
3	RS-485 LEDs Stato												
4	RS-232 LEDs Stato												
5	LEDs Varco 1												
6	Lettore <table style="margin-left: 20px;"> <tr> <td>+V</td> <td>Rosso</td> </tr> <tr> <td>SIGA/SIGB</td> <td>Bianco</td> </tr> <tr> <td>LED</td> <td>Marrone</td> </tr> <tr> <td>0V</td> <td>Nero</td> </tr> <tr> <td>0V (sirena)</td> <td>Giallo</td> </tr> <tr> <td>0V (tamper/DC - contatto porta)</td> <td>Blu</td> </tr> </table>	+V	Rosso	SIGA/SIGB	Bianco	LED	Marrone	0V	Nero	0V (sirena)	Giallo	0V (tamper/DC - contatto porta)	Blu
+V	Rosso												
SIGA/SIGB	Bianco												
LED	Marrone												
0V	Nero												
0V (sirena)	Giallo												
0V (tamper/DC - contatto porta)	Blu												
7	Pulsante Uscita (NO) <table style="margin-left: 20px;"> <tr> <td>RTE</td> <td>Blu</td> </tr> <tr> <td>0V</td> <td>Nero</td> </tr> </table>	RTE	Blu	0V	Nero								
RTE	Blu												
0V	Nero												
8	Contatto Porta												
9	Opzioni Collegamento serratura: <ul style="list-style-type: none"> • SAFE—collegare a NC • SECURE—collegare a NO 												
10	—												
11	Numero seriale e Barcode												
12	Pulsante One-Touch™												
13	LED Stato Sistema												
14	Terminali Alimentatore PSU												
15	Batteria Backup												
16	12V/24V nominale Alimentatore supplementare <table style="margin-left: 20px;"> <tr> <td>VIN</td> <td>Arancio</td> </tr> <tr> <td>0V</td> <td>Bianco</td> </tr> <tr> <td>MSTAT</td> <td>Rosa</td> </tr> <tr> <td>(Batteria) +</td> <td>Rosso</td> </tr> <tr> <td>(Batteria) -</td> <td>Nero</td> </tr> <tr> <td>Mettere</td> <td>Verde/Giallo</td> </tr> </table>	VIN	Arancio	0V	Bianco	MSTAT	Rosa	(Batteria) +	Rosso	(Batteria) -	Nero	Mettere	Verde/Giallo
VIN	Arancio												
0V	Bianco												
MSTAT	Rosa												
(Batteria) +	Rosso												
(Batteria) -	Nero												
Mettere	Verde/Giallo												
17	Collegamento PC RS-232 o Ethernet												
18	Tamper Armadio-Box (NC)												
19	Override/Emergenza varco (NC) <ul style="list-style-type: none"> • La rimozione del ponticello aziona la serratura • Non previsto come Emergenza FIRE OVERRIDE 												
20	Lettore Wiegand												

** Fare riferimento ai manuali per 3rd-party PSU

Modalità Test One Touch™

Per facilitare l'installazione e il collaudo, tramite il test One-Touch™ è possibile verificare la funzionalità dell'unità di controllo e dei lettori.

Test	Azione	Stato LEDS		Lettore	
		Unità di Controllo			
Funzionamento Normale		  Verde	System status: VERDE lampeggio normale		
		 Verde-Rosso-Giallo	Door status: tutti i LEDS OFF		
Modalità visualizza One-Touch™	Tenere premuto pulsante One-Touch™ per meno di 2 secondi. Provare tessere o portachiavi, azionare i pulsanti di uscita RTE e verificare stato LEDS. Esce automaticamente dopo 2 minuti.	  Verde	System status: VERDE lampeggio normale.	 Rosso	Funzionamento normale dei lettori.
		 Verde-Rosso-Giallo	Door status: VERDE ON, chiave valida al lettore.		
		 Verde-Rosso-Giallo	Door status: Door status: VERDE lampeggio, chiave non valida al lettore.		
		 Verde-Rosso-Giallo	Door status: ROSSO ON, porta aperta.		
		 Verde-Rosso-Giallo	Door status: GIALLO ON, RTE PULSANTE USCITA premuto.		
Modalità attivazioni One-Touch™	Tenere premuto pulsante One-Touch™ dai 2 ai 4 secondi.	  Verde	System status: VERDE lampeggio veloce.	 Verde	Le normali operazioni del Led del lettore cambiano, Esempio se normalmente è rosso diventa verde.
Lettori e Pulsanti di uscita RTE	Provare portachiavi o tessera ad ogni lettore (la serratura si deve aprire).	 Verde-Rosso-Giallo	Door status: Door status: VERDE Lampeggia 1 volta per SIGA-Lettore A 2 volte per SIGB Lettore B.	 Rosso	LED Lettore lampeggia 1 volta per SIGA Lettore 1 e 2 volte per SIGB Lettore 2.
	Premere i pulsanti di uscita RTE (la serratura si deve aprire).	 Verde-Rosso-Giallo	Door status: VERDE Lampeggia 3 volte GIALLO ON.	 Rosso	LED Lettore lampeggia 3 volte.
	Aprire la porta / Contatto porta.	 Verde-Rosso-Giallo	Door status: VERDE Lampeggia 4 volte ROSSO ON.	 Rosso	LED Lettore lampeggia 4 volte.
Test Relè ausiliari e Serratura	Provare portachiavi o tessera al lettore, premere pulsante di uscita RTE e aprire porta / Contatto porta contemporaneamente.		Il relè ausiliario corrispondente si deve attivare.		
	Rimuovere ponticello TAMP su 0V o azionare tamper.		Entrambi i relè ausiliari si devono attivare.		
	Rimuovere ponticello OVERRIDE su 0V o azionare tamper.		Il relè ausiliario corrispondente si deve attivare.		
Test Tamper e Override / Emergenza	Rimuovere ponticello TAMP su 0V dalla morsettiere.		Il relè ausiliario si deve attivare ma il relè porta non viene attivato.		
	Rimuovere ponticello OVERRIDE su 0V dalla morsettiere.		Entrambi i relè ausiliari si devono attivare. La porta si apre e aziona la serratura.		
Uscita dalla modalità Test One-Touch™	Tenere premuto pulsante One-Touch™ per meno di 2 secondi. L'unità di controllo esce automaticamente dalla modalità test dopo 1 ora o togliendo e ridando alimentazione.	  Verde	System status: VERDE ritorna al lampeggio normale	 Rosso	LED del lettore torna al suo stato normale.

Einführung

Dieses Dokument richtet sich an erfahrenes technisches Personal, das mit Geräten von PAC und den einschlägigen Arbeitssicherheitsbestimmungen vertraut ist.

Zusätzliche Informationen zur Softwareinstallation und -bedienung finden Sie in den mit der Verwaltungssoftware mitgelieferten Dokumentations- und Hilfedateien.



Alle ähnlichen Controller im System sollten die gleiche Firmware-Versionnummer haben.

Möglicherweise ist für den neuen Controller ein Firmware-Download erforderlich. Zu näheren Einzelheiten siehe die Hilfedatei.

Sabotage- und Überbrückungsklemme (NC)

Vor dem Einschalten ein kurzes Kabel verwenden, um Folgendes zu verbinden:

- Sabotage- (TAMP) und 0V-Klemmen
- Überbrückungs- (OVERRIDE) und 0V-Klemmen.

Die Überbrückung kann bei Bedarf für EOL-Betrieb konfiguriert werden.

RS-485-Anschluss

Falls geschirmte Kabel verwendet werden, die Abschirmung an einem Controller an der mit „SHIELD“ gekennzeichneten Erdungsklemme anschließen.



Nur beim ersten und letzten Controller in der Kette muss der RS-485-DIP-Schalter auf „IN“ eingestellt sein.

RS-485-LED	Beschreibung
ROT	Der Controller sendet Daten.
GRÜN	Ein anderer Controller sendet Daten im Netzwerk.

Gegen-EMK-Unterdrückung bei Schlössern

Alle Schlösser müssen mit einer Vorrichtung zur Unterdrückung der Gegen-EMK („Spannungsspitzen“) ausgestattet sein, die von den meisten elektrischen Auslösungsvorrichtungen – und insbesondere von Magnetschlössern – erzeugt wird.

Alle von PAC gelieferten Lesegeräte und Controller sind mit einem Metalloxidvaristor (MOV) ausgestattet.

Für Ströme > 1 A verwenden Sie bitte den mit dem Controller mitgelieferten großen MOV.

Für Ströme < 1A verwenden Sie bitte den mit dem Lesegerät mitgelieferten kleinen MOV.

Der MOV schützt den Controller gegen Langzeitschäden.































Soweit möglich, sollte dieses Bauteil immer an den Schlosskontakten angeschlossen werden. Falls die Schlosskontakte aus irgendwelchen Gründen unzugänglich sind, kann der MOV auch am Schlossausgang angeschlossen werden.

Die Schlossrelais sind durch einen mit dem RELAY COM-Anschluss in Reihe geschalteten 3-A-Schutzschalter geschützt. Sie werden automatisch zurückgesetzt, wenn die Überlast beseitigt wurde. Beide Schlossausgänge sind unabhängig voneinander.

1	RS-485-Anschluss																		
2	DIP-Schalter-Einstellungen <ol style="list-style-type: none"> 1. RS-485-Anschluss (IN <u>oder</u> OUT, Standard = OUT) 2. Lesegerät-Spannungswahlschalter (12/24 V <u>oder</u> 5 V, Standard = 12/24 V) 3. N/A 4. N/A 																		
3	RS-485-Status-LEDs																		
4	RS-232-Status-LEDs																		
5	LEDs Tür 1																		
6	Lesegerät <table border="0" style="margin-left: 20px;"> <tr> <td></td> <td>+V</td> <td>Rot</td> </tr> <tr> <td></td> <td>SIGA/SIGB</td> <td>Weiß</td> </tr> <tr> <td></td> <td>LED</td> <td>Braun</td> </tr> <tr> <td></td> <td>0V</td> <td>Schwarz</td> </tr> <tr> <td></td> <td>0V (Signaltongeber)</td> <td>Gelb</td> </tr> <tr> <td></td> <td>0V (Sabotage/DC – Türkontakt)</td> <td>Blau</td> </tr> </table>		+V	Rot		SIGA/SIGB	Weiß		LED	Braun		0V	Schwarz		0V (Signaltongeber)	Gelb		0V (Sabotage/DC – Türkontakt)	Blau
	+V	Rot																	
	SIGA/SIGB	Weiß																	
	LED	Braun																	
	0V	Schwarz																	
	0V (Signaltongeber)	Gelb																	
	0V (Sabotage/DC – Türkontakt)	Blau																	
7	Austrittsanforderung (NO) <table border="0" style="margin-left: 20px;"> <tr> <td></td> <td>RTE</td> <td>Blau</td> </tr> <tr> <td></td> <td>0V</td> <td>Schwarz</td> </tr> </table>		RTE	Blau		0V	Schwarz												
	RTE	Blau																	
	0V	Schwarz																	
8	Türkontakt																		
9	Schlossverdrahtungs-Optionen <ul style="list-style-type: none"> • FAIL SAFE – an NC anschließen • FOLGESCHADENSICHER – an NO anschließen 																		
10	—																		
11	Seriennummer und Barcode																		
12	One-Touch™-Taste																		
13	Systemstatus-LED																		
14	Stromversorgungsanschluss																		
15	Batteriepufferung																		
16	12V/24V-Netzteil nominal <table border="0" style="margin-left: 20px;"> <tr> <td></td> <td>VIN</td> <td>Orange</td> </tr> <tr> <td></td> <td>0V</td> <td>Weiß</td> </tr> <tr> <td></td> <td>MSTAT</td> <td>Rosa</td> </tr> <tr> <td></td> <td>(Batterie) +</td> <td>Rot</td> </tr> <tr> <td></td> <td>(Batterie) -</td> <td>Schwarz</td> </tr> <tr> <td></td> <td>MASSE</td> <td>Grün/Gelb</td> </tr> </table>		VIN	Orange		0V	Weiß		MSTAT	Rosa		(Batterie) +	Rot		(Batterie) -	Schwarz		MASSE	Grün/Gelb
	VIN	Orange																	
	0V	Weiß																	
	MSTAT	Rosa																	
	(Batterie) +	Rot																	
	(Batterie) -	Schwarz																	
	MASSE	Grün/Gelb																	
17	RS-232- oder Ethernetanschluss für PC																		
18	Sabotagekontakt (NC)																		
19	Türüberbrückung (NC) <ul style="list-style-type: none"> • Durch das Entfernen des Kurzschlusses wird das Sperrrelais aktiviert • NICHT für die Verwendung als FEUERÜBERSTEUERUNG ausgelegt 																		
20	Wiegand-Leser																		

One-Touch™-Testmodus

Zur Beschleunigung der Installation und des Testens gibt es einen One-Touch™-Testmodus, mit dem die Funktionsfähigkeit der Steuerung am Controller oder am Lesegerät getestet werden kann.

Test	Aktion	Überwachung			
		Controller	Lesegerät		
Normalbetrieb		  Grün	Systemstatus: GRÜN blinkt mit normaler Frequenz.		
		  Grün-Rot-Gelb	Türstatus: Alle LEDs aus.		
One-Touch™-Anzeigemodus	One-Touch™-Taste weniger als 2 Sekunden lang gedrückt halten. Schlüssel heranhelfen, RTE-Schalter drücken und LEDs beobachten. Wird nach 2 Minuten automatisch beendet.	  Grün	Systemstatus: GRÜN blinkt mit normaler Frequenz.	 Rot	Normaler Betrieb des Lesegeräts.
		  Grün-Rot-Gelb	Türstatus: GRÜN leuchtet; dem Lesegerät wurde ein gültiger Schlüssel präsentiert.		
		  Grün-Rot-Gelb	Türstatus: GRÜN blinkt; dem Lesegerät wurde ein ungültiger Schlüssel präsentiert.		
		  Grün-Rot-Gelb	Türstatus: ROT leuchtet; Tür öffnen.		
		  Grün-Rot-Gelb	Türstatus: GELB leuchtet; RTE-Schalter wurde gedrückt.		
One-Touch™-Aktivmodus	One-Touch™-Taste 2 bis 4 Sekunden lang gedrückt halten.	  Grün	Systemstatus: GRÜN blinkt schneller als normal.	 Grün	Der Normalzustand der Lesegerät-LED ändert sich. Wenn sie z. B. normalerweise rot leuchtet, wechselt sie zu grün.
Lesegerät- und Austrittsanforderungs-Test	An jedes Lesegerät einen Schlüssel heranhelfen (das Schloss wird aktiviert).	  Grün-Rot-Gelb	Türstatus: GRÜN blinkt einmal für SIGA, zweimal für SIGB.	 Rot	Lesegerät-LED blinkt einmal für SIGA, zweimal für SIGB.
	Austrittsanforderungs-Schalter drücken (Schloss wird aktiviert).	  Grün-Rot-Gelb	Türstatus: GRÜN blinkt dreimal und GELB leuchtet.	 Rot	Lesegerät-LED blinkt dreimal.
	Türkontakt öffnen.	  Grün-Rot-Gelb	Türstatus: GRÜN blinkt viermal und ROT leuchtet.	 Rot	Lesegerät-LED blinkt viermal.
Hilfs- und Schlossrelais-Test	Einen Schlüssel an ein Lesegerät heranhelfen, den Austrittsanforderungs-Schalter drücken und gleichzeitig den Türkontakt öffnen.		Das entsprechende Hilfsrelais wird aktiviert.		
	Brücke zu 0V am Sabotagekontakt entfernen oder den Stromkreis des Sabotagekontakts öffnen.		Beide Hilfsrelais werden aktiviert.		
	Brücke zu 0V an Notüberbrückung entfernen oder Sabotagekontakt-Stromkreis offen lassen.		Das Hilfsrelais wird aktiviert.		
Sabotage- und Überbrückungstest	Brücke zwischen TAMP und 0V am Sabotage- und Überbrückungsklemmenblock entfernen.		Das Hilfsrelais wird aktiviert, die Türrelais sind davon jedoch nicht betroffen.		
	Die Brücke zwischen OVRD und 0V am Sabotage- und Überbrückungsklemmenblock entfernen.		Hilfsrelais und Schlossrelais werden aktiviert, die Tür öffnet sich und das Schloss wird betätigt.		
One-Touch™-Aktivtestmodus beenden	One-Touch™-Taste weniger als 2 Sekunden lang gedrückt halten. Der One-Touch™-Testmodus wird nach einer Stunde und beim Aus- und Wiedereinschalten automatisch beendet.	  Grün	Systemstatus: GRÜN blinkt wieder mit normaler Frequenz.	 Rot	Die Lesegerät-LED kehrt zum Normalbetrieb zurück.

Introduction

Ce document est destiné aux techniciens expérimentés familiarisés avec les produits PAC, ainsi que les questions de santé et de sécurité.

La documentation et les fichiers d'aide fournis avec le logiciel d'administration expliquent l'installation et l'utilisation du logiciel.

Tous les contrôleurs semblables sur le système doivent avoir le même nombre de version de progiciels.

Un téléchargement du progiciel vers le nouveau contrôleur peut être nécessaire, consultez le fichier d'aide pour plus de détails.

Bornier anti-effraction et de neutralisation (NC)

Les commutateurs anti-effraction et de neutralisation étant normalement fermés, un câble de courte longueur doit être utilisé pour relier :

- les bornes Effraction (TAMP) et 0V.
 - les bornes Annulation d'urgence (OVERRIDE) et 0V.
- Configuration possible de l'OVRD pour fonctionnement en fin de ligne si nécessaire.

RS-485 Réseau câble

Lorsque des câbles blindés sont utilisés, connectez l'écran sur un contrôleur à la borne de terre intitulée « SHIELD ».

Seuls le premier et le dernier contrôleurs de la chaîne (et aucun autre) doivent être reliés au cavalier de terminaison RS-485 (réglé sur IN).

RS-485 DIODE	Description
ROUGE	Le contrôleur transmet des données
VERTE	Un autre contrôleur transmet des données sur le réseau

Suppression d'un verrou

Tous les verrous doivent impérativement être équipés d'un dispositif de suppression des renvois de FEM (« pointes ») générés par la plupart des équipements électriques, en particulier les verrous magnétiques.

Tous les lecteurs et contrôleurs livrés par PAC sont équipés d'un écréteur MOV.

Si des courants élevés sont utilisés (supérieurs à 1 A), utilisez l'écréteur MOV à **grande capacité** livré avec le **contrôleur**.

Si des courants peu élevés sont utilisés (inférieurs à 1 A), utilisez l'écréteur MOV à **capacité réduite** livré avec le **lecteur**. L'écréteur MOV protège le contrôleur contre les dommages à long terme.



















Dans la mesure du possible, ce dispositif doit équiper les bornes de verrou. Si, pour une raison ou pour une autre, celles-ci ne sont pas accessibles, l'écréteur MOV peut être installé sur les sorties de verrou.

Les relais de verrouillage sont protégés par un disjoncteur 3A en ligne avec le raccordement **RELAY COM**. Ils sont automatiquement réinitialisés lorsque la surcharge a été éliminée. Les deux sorties de verrouillage sont indépendantes.

1	RS-485 Réseau câble												
2	Paramètres commutateur DIP <ol style="list-style-type: none"> 1. RS-485 arrêt (IN ou OUT, par défaut = OUT) 2. Sélecteur de tension du lecteur (12/24V ou 5V, par défaut = 12/24V) 3. N/A 4. N/A 												
3	Voyants d'état RS-485												
4	Voyants d'état RS-232												
5	Voyants de PORTE 1												
6	Lecteur <table style="margin-left: 20px;"> <tr><td>+V</td><td>Rouge</td></tr> <tr><td>SIGA/SIGB</td><td>Blanc</td></tr> <tr><td>LED</td><td>Marron</td></tr> <tr><td>0V</td><td>Noir</td></tr> <tr><td>0V (alarme sonore)</td><td>Jaune</td></tr> <tr><td>0V (anti-effraction DC - contact de porte)</td><td>Bleu</td></tr> </table>	+V	Rouge	SIGA/SIGB	Blanc	LED	Marron	0V	Noir	0V (alarme sonore)	Jaune	0V (anti-effraction DC - contact de porte)	Bleu
+V	Rouge												
SIGA/SIGB	Blanc												
LED	Marron												
0V	Noir												
0V (alarme sonore)	Jaune												
0V (anti-effraction DC - contact de porte)	Bleu												
7	Requête de sortie (NO) <table style="margin-left: 20px;"> <tr><td>RTE</td><td>Bleu</td></tr> <tr><td>0V</td><td>Noir</td></tr> </table>	RTE	Bleu	0V	Noir								
RTE	Bleu												
0V	Noir												
8	Contact de porte												
9	Option de câblage de verrouillage : <ul style="list-style-type: none"> • SÉCURITÉ À ÉMISSION—connectez à NC • SÉCURITÉ À RUPTURE—connectez à NO 												
10	—												
11	Numéro de série et code à barres												
12	Bouton One-Touch™												
13	Voyant d'état du système												
14	Alimentation électrique												
15	Batterie de secours												
16	12V/24V nominal Unité d'alimentation <table style="margin-left: 20px;"> <tr><td>VIN</td><td>Orange</td></tr> <tr><td>0V</td><td>Blanc</td></tr> <tr><td>MSTAT</td><td>Rose</td></tr> <tr><td>(Batterie) +</td><td>Rouge</td></tr> <tr><td>(Batterie) -</td><td>Noir</td></tr> <tr><td>TERRE</td><td>Vert et jaune</td></tr> </table>	VIN	Orange	0V	Blanc	MSTAT	Rose	(Batterie) +	Rouge	(Batterie) -	Noir	TERRE	Vert et jaune
VIN	Orange												
0V	Blanc												
MSTAT	Rose												
(Batterie) +	Rouge												
(Batterie) -	Noir												
TERRE	Vert et jaune												
17	RS-232/PC ou connexion Ethernet												
18	Commutateur anti-effraction (NC)												
19	Annulation de porte (NC) <ul style="list-style-type: none"> • La suppression du court-circuit activera le relais de verrouillage • NON évalué pour une utilisation en tant que FIRE OVERRIDE 												
20	Lecteur Wiegand												

Mode Test One-Touch™

Pour accélérer l'installation et les essais, un mode de test One-Touch™ est fourni afin de permettre de tester la fonctionnalité du contrôleur à partir du contrôleur ou du lecteur.

Test	Activité	Observation			
		Contrôleur d'accès		Lecteur	
Fonctionnement normal		 Verte	État du système : la diode VERTE clignote à la vitesse normale.		
		 Verte-Rouge-Jaune	État de la porte : toutes les diodes sont éteintes		
Mode Affichage One-Touch™	Appuyez sur la touche One-Touch™ pendant moins de 2 secondes. Présentez des clés, appuyez sur les contacts RTE et observez les diodes. Quitte automatiquement après 2 minutes.	 Verte	État du système : la diode d'état VERTE clignote à la vitesse normale.	 Rouge	Fonctionnement normal du lecteur.
		 Verte-Rouge-Jaune	État de la porte : Diode VERTE allumée – une clé valide a été présentée au lecteur.		
		 Verte-Rouge-Jaune	État de la porte : Diode VERTE clignotante – une clé invalide a été présentée au lecteur.		
		 Verte-Rouge-Jaune	État de la porte : Diode ROUGE allumée – porte ouverte.		
		 Verte-Rouge-Jaune	État de la porte : Diode JAUNE allumée – un contact RTE a été actionné.		
Mode actif One-Touch™	Maintenez la touche One-Touch™ appuyée pendant 2 à 4 secondes.	 Verte	État du système : la diode VERTE clignote plus rapidement qu'à la normale.	 Verte	La diode indiquant le fonctionnement normal du lecteur change (par ex. si elle est rouge par défaut, elle devient verte.)
Test lecteur et demande de sortie	Présentez une clé à chaque lecteur (le verrou s'activera).	 Verte-Rouge-Jaune	État de la porte : La diode VERTE clignote une fois pour SIGA, deux fois pour SIGB.	 Rouge	La diode du lecteur clignote une fois pour SIGA, deux fois pour SIGB.
	Appuyez sur le contact Requête de sortie (le verrou s'activera).	 Verte-Rouge-Jaune	État de la porte : La diode VERTE clignote trois fois et la JAUNE est allumée.	 Rouge	La diode du lecteur clignote trois fois.
	Ouvrez le contact de la porte.	 Verte-Rouge-Jaune	État de la porte : La diode VERTE clignote trois fois et la JAUNE est allumée.	 Rouge	La diode du lecteur clignote quatre fois.
Test des relais auxiliaires et relais de verrouillage	Présentez une clé au lecteur, appuyez sur le contact Requête de sortie et ouvrez le contact de porte simultanément.		Le relais auxiliaire approprié est activé.		
	Retirez le lien vers 0V sur le contacteur d'effraction ou le contacteur d'effraction à circuit ouvert.		Les deux relais auxiliaires sont activés.		
	Retirez le lien vers 0V sur le contact d'annulation d'urgence ou le contact d'effraction à circuit ouvert.		Le relais auxiliaire est activé.		
Test d'effraction et annulation d'urgence	Supprimez le lien entre TAMP et 0V sur le bornier Effraction et Annulation d'urgence.		Le relais auxiliaire est activé mais les relais de portes ne sont pas affectés.		
	Supprimez le lien entre OVRD et 0V sur le bornier Effraction et Annulation d'urgence.		Les relais auxiliaires et les relais de verrouillage sont activés, la porte s'ouvre et le verrou est actionné.		
Quittez le mode Actif Test One-Touch™	Appuyez sur la touche One-Touch™ pendant moins de 2 secondes. Le mode Test One-Touch™ s'arrêtera automatiquement après 1 heure et lors de la mise sur et hors tension.	 Verte	État du système : La diode VERTE recommence à clignoter à sa vitesse normale.	 Rouge	La diode du lecteur reprend son fonctionnement normal.

Introducción

Este documento va dirigido a ingenieros con experiencia que estén familiarizados con los productos PAC y con aspectos de salud y seguridad.

En la documentación y los archivos de ayuda suministrados con el software de gestión se proporciona más información sobre la instalación y funcionamiento del software.

 **Se recomienda que todos los controladores similares en el sistema cuenten con el mismo número de versión del firmware.**

Es posible que sea necesario la descarga del firmware correspondiente del nuevo controlador, vea el archivo de ayuda para obtener más detalles.

Terminal de manipulación fraudulenta y conmutación (NC)

Antes de encender, utilice un trozo de cable pequeño para enlazar los

- terminales de manipulación (TAMP) y 0 V.
- terminales de conmutación (OVERRIDE) y 0 V.

Se puede configurar la conmutación de mando para la operación de EOL si es necesario.

Conexión de RS-485

Si se utilizan cables blindados, conecte el blindaje de un controlador al terminal de masa etiquetado "SHIELD".

 **El primer y último controladores de la cadena deben tener conectado el puente de terminación RS-485 (fijado en IN).**

LED de RS-485	Descripción
ROJO	El controlador está transmitiendo datos
VERDE	Otro controlador está transmitiendo datos en la red

Supresión de bloqueo

Todos los bloqueos tienen que contar con un medio de supresión de campos electromagnéticos ('puntas') generados por la mayoría de los liberadores eléctricos, especialmente por los cierres magnéticos.

Todos los lectores y controladores suministrados por PAC se suministran con un varistor de óxido metálico (MOV por sus siglas en inglés).

Para corrientes superiores a >1A, utilice el MOV grande suministrado con el **controlador**.

Para corrientes inferiores a <1A, utilice el MOV pequeño suministrado con el **lector**.

El MOV evita que se produzcan daños a largo plazo en el controlador.

Siempre que sea posible, este dispositivo deberá instalarse a través de las terminales del bloqueo. Si, por cualquier motivo, las terminales del bloqueo resultan inaccesibles, el MOV podrá instalarse a través de la salida de bloqueo.





















Los relés de cierre están protegidos por un cortocircuito de 3 A en línea con la conexión de **RELAY COM** [comunicación de relé]. Estos se pondrán a cero automáticamente cuando se haya retirado la sobrecarga; ambas salidas de bloqueo son independientes.

Llave a Diagrama eléctrico en la página 2-3

1	Conexión de RS-485													
2	Configuración de interruptor DIP <ol style="list-style-type: none"> 1. Terminación RS-485 (ENTRADA o SALIDA, por defecto = SALIDA) 2. Selector de voltaje del lector (12/24V o 5V, por defecto = 12/24V) 3. N/A 4. N/A 													
3	Indicadores LED de estado RS-485													
4	Indicadores LED de estado RS-232													
5	Indicadores LED de puerta 1													
6	Lector	<table style="margin-left: 20px;"> <tr><td>+V</td><td>Rojo</td></tr> <tr><td>SIGA/SIGB</td><td>Blanco</td></tr> <tr><td>LED</td><td>Marrón</td></tr> <tr><td>0V</td><td>Negro</td></tr> <tr><td>0V (sounder)</td><td>Amarillo (sonido)</td></tr> <tr><td>0V (tamper/DC - door contact)</td><td>Azul (manip.fraud.)</td></tr> </table>	+V	Rojo	SIGA/SIGB	Blanco	LED	Marrón	0V	Negro	0V (sounder)	Amarillo (sonido)	0V (tamper/DC - door contact)	Azul (manip.fraud.)
+V	Rojo													
SIGA/SIGB	Blanco													
LED	Marrón													
0V	Negro													
0V (sounder)	Amarillo (sonido)													
0V (tamper/DC - door contact)	Azul (manip.fraud.)													
7	Solicitud de salida (NO) RTE (Solicitud de salida)	<table style="margin-left: 20px;"> <tr><td>Azul (manip.fraud.)</td></tr> <tr><td>0V Negro</td></tr> </table>	Azul (manip.fraud.)	0V Negro										
Azul (manip.fraud.)														
0V Negro														
8	Contacto de puerta													
9	Opciones de cableado de cerradura	<ul style="list-style-type: none"> • BLOQUEO CON ALIMENTACIÓN—conectar a NC (normalmente cerrado) • DESBLOQUEO CON ALIMENTACIÓN—conectar a NO (normalmente abierto) 												
10	—													
11	Número de serie y código de barras													
12	Botón One-Touch™													
13	LED de estado del sistema													
14	Acceso a alimentación													
15	Batería de reserva													
16	Fuente de alimentación 12 V/24 V nominal	<table style="margin-left: 20px;"> <tr><td>VIN</td><td>Naranja</td></tr> <tr><td>0V</td><td>Blanco</td></tr> <tr><td>MSTAT</td><td>Rosa</td></tr> <tr><td>(Batería) +</td><td>Rojo</td></tr> <tr><td>(Batería) -</td><td>Negro</td></tr> <tr><td>MASA</td><td>Verde/amarillo</td></tr> </table>	VIN	Naranja	0V	Blanco	MSTAT	Rosa	(Batería) +	Rojo	(Batería) -	Negro	MASA	Verde/amarillo
VIN	Naranja													
0V	Blanco													
MSTAT	Rosa													
(Batería) +	Rojo													
(Batería) -	Negro													
MASA	Verde/amarillo													
17	Puerto RS-232 de PC o conexión ethernet													
18	Interruptor manip. fraud. (NC)													
19	Anulación de puerta (NC)	<ul style="list-style-type: none"> • Eliminación del relé de bloqueo de operación corta • NO clasificado para uso como ANULACIÓN DE FUEGO 												
20	Lector Wiegand													

Modo de prueba One-Touch™

Para acelerar la instalación y efectuar pruebas, se provee la prestación de pruebas One-Touch™, que permite probar la funcionalidad del controlador en el controlador o el lector.

Prueba	Acción	Observación		
		Controlador	Lector	
Operación normal		  Verde	Estado del sistema: El LED VERDE parpadea a un ritmo normal.	
		 Verde-Rojo-Amarillo	Estado de la puerta: Todos los indicadores LED apagados.	
Modo de visualización de One-Touch™	Mantenga pulsado el botón One-Touch™ menos de 2 segundos. Presente claves y pulse los interruptores de RTE y observe los LED. Sale automáticamente tras 2 minutos.	  Verde	El LED VERDE del Estado del sistema parpadea a un ritmo normal.	
		 Verde-Rojo-Amarillo	Estado de la puerta: VERDE encendido, se ha presentado una clave válida al lector.	
		 Verde-Rojo-Amarillo	Estado de la puerta: VERDE parpadea, se ha presentado una clave no válida al lector.	
		 Verde-Rojo-Amarillo	Estado de la puerta: ROJO encendido, puerta abierta	
		 Verde-Rojo-Amarillo	Estado de la puerta: AMARILLO encendido, se ha pulsado el interruptor RTE.	
Modo activo de One-Touch™	Mantenga pulsado el botón One-Touch™ durante 2-4 segundos.	  Verde	 Verde	Cambia la operación normal del LED del lector, p.ej., si el rojo es el color por defecto, cambia a verde.
Prueba de lector y de solicitud de salida	Presente una clave a cada lector (se activará la cerradura).	 Verde-Rojo-Amarillo	 Rojo	El LED del lector parpadea una vez para SIGA y dos para SIGB.
	Pulse el interruptor de Solicitud de salida (se activará la cerradura).	 Verde-Rojo-Amarillo	 Rojo	El LED del lector parpadea tres veces.
	Abra el contacto de la puerta.	 Verde-Rojo-Amarillo	 Rojo	El LED del lector parpadea cuatro veces.
Pruebas de relés auxiliares y de cerraduras	Presente una clave al lector, pulse el interruptor de Solicitud de salida y abra el contacto de la puerta simultáneamente.			Se activa el relé auxiliar apropiado.
	Retire la conexión a 0 V de la manipulación o abra el interruptor de manipulación del circuito.			Se activan ambos relés auxiliares.
	Retire la conexión a 0 V de la conmutación de mando de emergencia o deje abierto el interruptor de manipulación de circuito.			Se activa el relé auxiliar.
Prueba de manipulación y conmutación de mando	Retire la conexión entre TAMP [Manipulación] y 0 V en el bloque terminal de Manipulación y conmutación de mando.			Se activa el relé auxiliar pero los relés de puerta no se ven afectados.
	Retire la conexión entre OVRD [Conmutación de mando] y 0 V en el bloque terminal de Manipulación y conmutación de mando.			Tanto los relés auxiliares como los de cerradura se activan, se abre la puerta y la cerradura funciona.
Salida del modo activo de prueba One-Touch™	Mantenga pulsado el botón One-Touch™ menos de 2 segundos. El modo de prueba One-Touch™ se desactivará automáticamente transcurrida 1 hora y al desenergizar y energizar.	  Verde	 Rojo	El LED del lector vuelve a su funcionamiento normal.

Inledning

Detta dokument är avsett för erfarna tekniker som har god kännedom om PAC-produkterna och om hälso- och säkerhetsbestämmelser.

Mer information om mjukvaruinstallation och -användning finns i dokumentationen och hjälpfilerna som tillhandahålls med administrationsmjukvaran.



Alla liknande styrenheter i systemet bör ha samma version av firmware.

Det kan vara nödvändigt att ladda ner firmware på den nya styrenheten, se hjälpfilen för mer information.

Anslutning för manipulering och forcering (NC)

Använd en kort kabelbit för att bygla mellan anslutningarna:

- manipulering (TAMP) och 0V.
- forcering (OVERRIDE) och 0V.

Forcering kan konfigureras för EOL-funktion om det krävs.

Anslutning av RS-485

Om avskärmade kablar används ska skärmen på en styrenhet anslutas till jordningsterminalen märkt "SHIELD".



Endast den första och den sista styrenheten i kedjan (inga andra) måste ha RS-485 termineringsbygel inställd på "IN".

Lysdioden RS-485	Beskrivning
RÖD	Styrenheten överför data
GÖRN	En annan styrenheten överför data på nätverket

Läsundertryckning

Alla läs måste vara utrustade med en anordning för att undertrycka spänningsspikar som genereras av elektrisk utrustning, i synnerhet magnetlås.

Alla läsare och styrenheter som levereras av PAC är utrustade med en Metall- Oxid-Varistor (MOV).

För ström > 1A, använd den stora MOV-varistorn som levererades med **styrenheten**.

För ström < 1A, använd den lilla MOV-varistorn som levererades med **läsaren**.

MOV-varistorn förhindrar att styrenheten utsätts för långvarig skada.



















När det är möjligt bör denna enhet monteras på motsatt sida från lästerminalerna. Om lästerminalerna av någon anledning inte går att nå, kan MOV-varistorn monteras på motsatt sida av låsutgången.

Läsreläerna skyddas av en 3A krets brytare i linje med **RELAY COM**-anslutningen. Dessa kommer automatiskt att återställas när överbelastningen har tagits bort. Båda låsutgångarna är oberoende.

1	RS-485-anslutning												
2	Inställning av DIP-brytare <ol style="list-style-type: none"> 1. RS-485 avslutning (IN eller UT, standard = UT) 2. Väljare för läsarspanning (12/24V eller 5V, standard = 12/24V) 3. N/A 4. N/A 												
3	RS-485 Statuslysdioder												
4	RS-232 Statuslysdioder												
5	Lysdioder Dörr 1												
6	Läsare <table> <tr> <td>+V</td> <td>Röd</td> </tr> <tr> <td>SIGA/SIGB</td> <td>Vit</td> </tr> <tr> <td>LED</td> <td>Brun</td> </tr> <tr> <td>0V</td> <td>Svart</td> </tr> <tr> <td>0V (ljud)</td> <td>Gul</td> </tr> <tr> <td>0V (manipulering/DC-dörrkontakt)</td> <td>Blå</td> </tr> </table>	+V	Röd	SIGA/SIGB	Vit	LED	Brun	0V	Svart	0V (ljud)	Gul	0V (manipulering/DC-dörrkontakt)	Blå
+V	Röd												
SIGA/SIGB	Vit												
LED	Brun												
0V	Svart												
0V (ljud)	Gul												
0V (manipulering/DC-dörrkontakt)	Blå												
7	Förfrågan om utgång (NO) <table> <tr> <td>RTE</td> <td>Blå</td> </tr> <tr> <td>0V</td> <td>Svart</td> </tr> </table>	RTE	Blå	0V	Svart								
RTE	Blå												
0V	Svart												
8	Dörrkontakt												
9	Alternativ för låskabeldragning: <ul style="list-style-type: none"> • FAIL SAFE—anslut till NC • FAIL SECURE—anslut till NO 												
10	—												
11	Serienummer och streckkod												
12	One-Touch™-knapp												
13	Lysdiod för systemstatus												
14	Matning												
15	Reservbatteri												
16	12V/12-28V Spänningsmatning <table> <tr> <td>VIN</td> <td>Orange</td> </tr> <tr> <td>0V</td> <td>Vit</td> </tr> <tr> <td>MSTAT</td> <td>Rosa</td> </tr> <tr> <td>(Batteri) +</td> <td>Röd</td> </tr> <tr> <td>(Batteri) -</td> <td>Svart</td> </tr> <tr> <td>JORDNING</td> <td>Grön/Gul</td> </tr> </table>	VIN	Orange	0V	Vit	MSTAT	Rosa	(Batteri) +	Röd	(Batteri) -	Svart	JORDNING	Grön/Gul
VIN	Orange												
0V	Vit												
MSTAT	Rosa												
(Batteri) +	Röd												
(Batteri) -	Svart												
JORDNING	Grön/Gul												
17	PC RS-232 eller Ethernetanslutning												
18	Manipuleringsbrytare (NC)												
19	Dörröverstyrning (NC) <ul style="list-style-type: none"> • Borttagning av kortslutning kommer att aktivera läsreläet • INTE klassad för användning som en BRAND ÅSNITTRING 												
20	Wiegand-läsare												

One-Touch™ Testläge

För att det ska gå snabbare att installera och testa styrsystemet medföljer testsystemet för One-Touch™ som gör att systemet kan testas vid styrenheten eller läsaren.

Test	Åtgärd	Observation			
		Styrenhet	Läsare		
Normal funktion		 Grön	Systemstatus: Den GRÖNA systemstatuslysdioden blinkar med normal hastighet.		
		 Grön-Röd-Gul	Dörrstatus: Alla lysdioder är av.		
One-Touch™ visningsläge	Håll ner One-Touch™-knappen högst 2 sekunder. Presentera nycklarna och tryck på RTE-omkopplarna och observera lysdioderna. Avslutas automatiskt efter 2 minuter.	 Grön	Systemstatus GRÖN blinkar med normal hastighet.	 Röd	Normal funktion hos läsaren.
		 Grön-Röd-Gul	Dörrstatus: GRÖN lyser, giltig nyckel har presenterats för läsaren.		
		 Grön-Röd-Gul	Dörrstatus: GRÖN blinkar, ogiltig nyckel har presenterats för läsaren.		
		 Grön-Röd-Gul	Dörrstatus: RÖD lyser, dörr är öppen.		
		 Grön-Röd-Gul	Dörrstatus: GUL lyser, RTE-omkopplaren har tryckts in.		
One-Touch™ aktivt läge	Håll ner One-Touch™-knappen under 2 till 4 sekunder.	 Grön	Systemstatus: GRÖN blinkar snabbare än normalt.	 Grön	Normalfunktionen för läsarens lysdiod ändras, t.ex. om standardinställningen är att den lyser rött, ändras detta till grönt.
Test av läsare och förfrågan om utgång	Presentera en nyckel för varje läsare (läset aktiveras).	 Grön-Röd-Gul	Dörrstatus: GRÖN blinkar en gång för SIGA, två gånger för SIGB.	 Röd	Lysdioden för läsaren blinkar en gång för SIGA, två gånger för SIGB.
	Tryck på Förfrågan om utgång (läset aktiveras).	 Grön-Röd-Gul	Dörrstatus: GRÖN blinkar tre gånger, och GUL är tänd.	 Röd	Lysdioden för läsaren blinkar tre gånger.
	Öppna dörrkontakten.	 Grön-Röd-Gul	Dörrstatus: GRÖN blinkar fyra gånger, och RÖD är tänd.	 Röd	Lysdioden för läsaren blinkar fyra gånger.
Test av extrarelä och läsrelä	Visa en nyckel för en läsare, tryck på omkopplaren Förfrågan om utgång och öppna samtidigt dörrkontakten.		Det aktuella extrarelät aktiveras.		
	Ta bort kopplingen till 0V för brytaren som avser manipulering eller avbrott.		Båda extrareläerna aktiveras.		
	Ta bort kopplingen till 0V för forcering (förbikoppling) i nödfall eller låt den kretsen för manipulering vara öppen.		Extrarelät aktiveras.		
Test av manipulering och forcering	Bryt anslutningen mellan TAMP och 0V på blocket Tamper & Override.		Extrarelät aktiveras, men dörrrens reläer påverkas inte.		
	Bryt anslutningen mellan OVRD och 0V på blocket Tamper & Override.		Både extra- och läsreläerna aktiveras, dörren öppnas och läset fungerar.		
Avsluta One-Touch™ aktivt testläge	Håll ner One-Touch™-knappen högst 2 sekunder. Testläget One-Touch™ avslutas automatiskt efter 1 timme, samt vid avstängning och start.	 Grön	Systemstatus: GRÖN blinkar med normal hastighet.	 Röd	Lysdioden för läsaren återgår till normalt läge.

Inleiding

Dit document is bedoeld voor ervaren technici die bekend zijn met PAC-producten en gezondheids- en veiligheidsaspecten. Aanvullende informatie over de installatie en bediening van software staat vermeld in de documentatie en de administratiesoftware bevat hulpbestanden.

Alle gelijkaardige regeleenheden op het systeem moeten over hetzelfde firmware-versienummer beschikken.

Eventueel dient op de nieuwe regeleenheid firmware te worden gedownload, zie het hulpbestand voor nadere informatie.

Aansluitpunten Tamper (ongeoorloofd gebruik) en Override (uitschakelen) (NC)

Gebruik vóór het opstarten een kort stuk kabel om de

- aansluitpunten Tamper (TAMP) en 0V te verbinden.
- aansluitpunten Override (OVERRIDE) en 0V te verbinden.

Override kan indien gewenst voor EOL-bedrijf worden geconfigureerd.

RS-485 aansluiting

Bij gebruik van afgeschermd kabels moet de afscherming op één regeleenheid op de aardingsklem met het label "SHIELD" worden aangesloten.

Uitsluitend de RS-485 afsluitjumper van de eerste en laatste regeleenheid in de reeks moet op "IN" worden ingesteld.

RS-485 led	Beschrijving
ROOD	De regeleenheid draagt gegevens over
GROEN	Een andere regeleenheid draagt gegevens over op het netwerk

Slotontstoring

Alle sloten moeten worden uitgerust met een mechanisme voor de onderdrukking van tegenelektromagnetische kracht (spanningspieken), die door de meeste ontgrendelingsmechanismen, vooral magnetische sloten, wordt gegeneerd.

Alle lezers en regeleenheden die door PAC worden geleverd zijn voorzien van een metaaloxidevaristor (MOV).

Gebruik voor stroomsterkten > 1 A de grote MOV die bij de **regeleenheid** wordt meegeleverd.

Gebruik voor stroomsterkten < 1 A de kleine MOV die bij de **lezer** wordt meegeleverd.

















De MOV voorkomt langetermijnschade aan de regeleenheid. Indien mogelijk dient dit apparaat over de aansluitpunten heen te worden aangebracht. Mochten de aansluitpunten om welke reden dan ook ontoegankelijk zijn, dan kan de MOV over de slotuitgang-aansluiting heen aan worden gebracht.

De slotrelais worden beschermd door een stroombreker van 3 A in lijn met de **RELAY COM**-aansluiting. Deze worden automatisch gereset zodra de overbelasting is hersteld; beide slotuitgangen zijn onafhankelijk.

1	RS-485 aansluiting																		
2	Instellingen afsluitjumper <ol style="list-style-type: none"> 1. RS-485 terminatie (IN of OUT, standaard = OUT) 2. Lezer spanningskeuzeschakelaar (12/24V or 5V, standaard = 12/24V) 3. N/A 4. N/A 																		
3	RS-485 statusleds																		
4	RS-232 statusleds																		
5	Leds deur 1																		
6	Lezer <table border="0"> <tr> <td></td> <td>+V</td> <td>Rood</td> </tr> <tr> <td></td> <td>SIGA/SIGB</td> <td>Wit</td> </tr> <tr> <td></td> <td>Led</td> <td>Bruin</td> </tr> <tr> <td></td> <td>0V</td> <td>4 Zwart</td> </tr> <tr> <td></td> <td>0V (sonder)</td> <td>5 Geel</td> </tr> <tr> <td></td> <td>0V (tamper/DC - deurcontact)</td> <td>6 Blauw</td> </tr> </table>		+V	Rood		SIGA/SIGB	Wit		Led	Bruin		0V	4 Zwart		0V (sonder)	5 Geel		0V (tamper/DC - deurcontact)	6 Blauw
	+V	Rood																	
	SIGA/SIGB	Wit																	
	Led	Bruin																	
	0V	4 Zwart																	
	0V (sonder)	5 Geel																	
	0V (tamper/DC - deurcontact)	6 Blauw																	
7	Verzoek uitgang (NO) <table border="0"> <tr> <td></td> <td>RTE</td> <td>Blauw</td> </tr> <tr> <td></td> <td>0V</td> <td>Zwart</td> </tr> </table>		RTE	Blauw		0V	Zwart												
	RTE	Blauw																	
	0V	Zwart																	
8	Deurcontact																		
9	Bedradingsopties slot: <ul style="list-style-type: none"> • FAIL-SAFE—sluit aan op NC • FAIL-SECURE—sluit aan op NO 																		
10	—																		
11	Serienummer en barcode																		
12	One-Touch™-knop																		
13	Statusled systeem																		
14	Stroomtoevoer																		
15	Reservebatterij																		
16	12V/24V-netadapter nominell <table border="0"> <tr> <td></td> <td>VIN</td> <td>Oranje</td> </tr> <tr> <td></td> <td>0V</td> <td>Wit</td> </tr> <tr> <td></td> <td>MSTAT</td> <td>Roze</td> </tr> <tr> <td></td> <td>(batterij) +</td> <td>Rood</td> </tr> <tr> <td></td> <td>(batterij) -</td> <td>Zwart</td> </tr> <tr> <td></td> <td>AARDE</td> <td>Groen/Geel</td> </tr> </table>		VIN	Oranje		0V	Wit		MSTAT	Roze		(batterij) +	Rood		(batterij) -	Zwart		AARDE	Groen/Geel
	VIN	Oranje																	
	0V	Wit																	
	MSTAT	Roze																	
	(batterij) +	Rood																	
	(batterij) -	Zwart																	
	AARDE	Groen/Geel																	
17	PC RS-232 of ethernetverbinding																		
18	Tamper-schakelaar (NC)																		
19	Deur opheffen (NC) <ul style="list-style-type: none"> • Verwijdering van de kortsluiting zal het vergrendelingsrelais activeren • NIET geschikt voor gebruik als BRAND OVERRIDE 																		
20	Wiegand-lezer																		

One Touch™-testfunctie

De One-Touch™-testfunctie versnelt het installeren en testen, waardoor de werking van de regelaar op de regelaar van lezer kan worden getest.

Test	Actie	Observatie			
		Regelaar	Lezer		
Normaal bedrijf		 Groen	Systeemstatus: GROEN knippert op normale snelheid.		
		 Groen-Rood-Geel	Deurstatus: Alle leds zijn uit.		
One-Touch™-beeldmodus	Houd de One-Touch™-knop korter dan 2 seconden ingedrukt. Toon de sleutels, druk op de RTE-schakelaars en observeer de leds. Automatische uitschakeling na 2 minuten.	 Groen	Systeemstatus GROEN knippert op normale snelheid.		
		 Groen-Rood-Geel	Deurstatus: GROEN aan, geldige sleutel aan lezer getoond.		
		 Groen-Rood-Geel	Deurstatus: GROEN knippert, ongeldige sleutel aan lezer getoond.		
		 Groen-Rood-Geel	Deurstatus: ROOD aan, deur open.		
		 Groen-Rood-Geel	Deurstatus: GEEL aan, RTE-schakelaar is ingedrukt.		
One-Touch™ actieve modus	Houd de One-Touch™-knop 2 tot 4 seconden ingedrukt.	 Groen	Systeemstatus: GROEN knippert sneller dan normaal.	 Groen	De led voor normaal bedrijf van de lezer verandert, bijv. indien standaard rood is, wordt hij groen.
Testen lezer en Verzoek uitgang	Toon elke lezer een sleutel (het slot wordt geactiveerd).	 Groen-Rood-Geel	Deurstatus: GROEN knippert één keer voor SIGA, twee keer voor SIGB.	 Rood	Led van lezer knippert één keer voor SIGA, twee keer voor SIGB.
	Druk op de schakelaar Verzoek uitgang (het slot wordt geactiveerd).	 Groen-Rood-Geel	Deurstatus: GROEN knippert drie keer en GEEL is aan.	 Rood	Led van lezer knippert drie keer.
	Open het deurcontact.	 Groen-Rood-Geel	Deurstatus: GROEN knippert vier keer en ROOD is aan.	 Rood	Led van lezer knippert vier keer.
Testen neven- en slotrelais	Toon een sleutel aan een lezer, druk op de schakelaar Verzoek uitgang en open gelijktijdig het deurcontact.		Het betreffende nevenrelais is geactiveerd.		
	Verwijder de verbinding naar 0V op de tamper-schakelaar of de open-circuit tamper-schakelaar.		Beide nevenrelais worden geactiveerd.		
	Elimineer de verbinding naar 0V op de nooduitschakeling of laat de open-circuit tamper-schakelaar onveranderd.		Het nevenrelais is geactiveerd.		
Testen Tamper en Override	Verwijder de verbinding tussen TAMP en 0V op het klemmenblok Tamper & Override.		Het nevenrelais is geactiveerd maar de deurrelais blijven onveranderd.		
	Verwijder de verbinding tussen OVRD en 0V op het klemmenblok Tamper & Override.		Beide neven- en slotrelais zijn geactiveerd, de deuren gaan open en het slot functioneert.		
De One-Touch™ actieve testfunctie verlaten	Houd de One-Touch™-knop korter dan 2 seconden ingedrukt. De One-Touch™-testfunctie wordt na 1 uur en bij een tijdelijke stroomuitval automatisch uitgeschakeld.	 Groen	Systeemstatus: GROEN knippert weer op normale snelheid.	 Rood	Led van lezer keert terug naar normaal bedrijf.

Innledning

Dette dokumentet er ment for erfarne teknikere som er kjent med PAC-produkter, og helse- og sikkerhetshensyn.

Ytterligere informasjon om programvareinstallasjon og -drift er gitt i dokumentasjonen og hjelpefilene som følger med administrasjonsprogramvaren.

 **Alle lignende kontrollere på systemet skal ha samme fastvareversjonsnummer.**

Det kan være nødvendig å laste ned fastvare til den nye kontrolleren, se hjelpefilen for ytterligere detaljer.

Sabotasje- og overstyringsterminal (NC)

Bruk en kort kabel, før driftsstart, for å forbinde:

- sabotasje- (TAMP) og 0V-klemmene,
- overstyrings- (OVRD) og 0V-klemmene.

OVRD kan ved behov konfigureres for EOL-bruk.

RS-485-tilkobling

Når skjermede kabler brukes, kobler du skjermen på en kontrollertil jordklemmen merket "SHIELD".

 **Den første og den siste styreenheten i kjeden (ingen andre) må ha RS-485- jumperen innstilt på "IN".**

Lysdioden RS-485	Beskrivelse
RØD	Styreenheten overfører data
Grønn	En annen styreenhet overfører data på nettverket

Lås EMF-demping

Alle låser må utstyres med en enhet som demper elektromotoriske spenningsspisser som genereres av de fleste elektriske frikoplingsenheter, særlig magnetlåser .

Alle lesere og styreenheter fra PAC leveres med en metalloksidvaristor (MOV).

For strøm >1A bruk den store MOV-varisatoren som ble levert med **kontrolleren**.

For strøm <1A bruk den lille MOV-varisatoren som ble levert med **leseren**.



















MOV-varistoren hindrer langtidsskader på styreenheten. Enheten skal alltid monteres over låskontaktene når dette er mulig. Hvis låskontaktene av en eller annen grunn er utilgjengelige, kan MOV-varistoren monteres over låsutgangen.

Låsereléene er beskyttet av en overbelastningsbryter på 3A på samme linje som **RELAY COM**-tilkoblingen. De blir automatisk tilbakestilt når overbelastningen er fjernet. Begge låsutgangene er uavhengige av hverandre.

1	RS-485-forbindelse												
2	Jumperinnstillinger <ol style="list-style-type: none"> 1. RS-485- terminering (INN eller UT, standard = UT) 2. Spenningsvelger for leser (12/24V eller 5V, standard = 12/24V) 3. N/A 4. N/A 												
3	Lysdioder for RS485-status												
4	Lysdioder for RS-232-status												
5	Lysdioder for Dør 1												
6	Leser <table style="margin-left: 20px;"> <tr><td>+V</td><td>Rød</td></tr> <tr><td>SIGA/SIGB</td><td>Hvit</td></tr> <tr><td>Lysdiode</td><td>Brun</td></tr> <tr><td>0V</td><td>Sort</td></tr> <tr><td>0V (summer)</td><td>Gul</td></tr> <tr><td>0V (sabotasje/DC - dørkontakt)</td><td>Blå</td></tr> </table>	+V	Rød	SIGA/SIGB	Hvit	Lysdiode	Brun	0V	Sort	0V (summer)	Gul	0V (sabotasje/DC - dørkontakt)	Blå
+V	Rød												
SIGA/SIGB	Hvit												
Lysdiode	Brun												
0V	Sort												
0V (summer)	Gul												
0V (sabotasje/DC - dørkontakt)	Blå												
7	Forespørsel om utgang (NO) <table style="margin-left: 20px;"> <tr><td>RTE</td><td>Blå</td></tr> <tr><td>0V</td><td>Sort</td></tr> </table>	RTE	Blå	0V	Sort								
RTE	Blå												
0V	Sort												
8	Dørkontakt												
9	Kablingsvalg for lås <ul style="list-style-type: none"> • FEILSIKKER – koble til NC • FEILSIKKER – koble til NO 												
10	—												
11	Serienummer og strekkode												
12	One-Touch™-knapp												
13	Lysdioder for systemstatus												
14	Strømtilgang												
15	Reservebatteri												
16	12V/12-28V strømforsyningsenhet <table style="margin-left: 20px;"> <tr><td>VIN</td><td>Oransje</td></tr> <tr><td>0V</td><td>Hvit</td></tr> <tr><td>MSTAT</td><td>Rosa</td></tr> <tr><td>(Batteri) +</td><td>Rød</td></tr> <tr><td>(Batteri) -</td><td>Sort</td></tr> <tr><td>JORD</td><td>Grønn/Gul</td></tr> </table>	VIN	Oransje	0V	Hvit	MSTAT	Rosa	(Batteri) +	Rød	(Batteri) -	Sort	JORD	Grønn/Gul
VIN	Oransje												
0V	Hvit												
MSTAT	Rosa												
(Batteri) +	Rød												
(Batteri) -	Sort												
JORD	Grønn/Gul												
17	RS-232/PC eller Ethernet-tilkobling												
18	Sabotasjebryter (NC)												
19	Dørstyring (NC) <ul style="list-style-type: none"> • Fjerning av kortslutning vil aktivere låsereléet • IKKE vurdert for bruk som BRANN-OVERRID 												
20	Wiegand-leser												

One Touch™ Test Mode

For at det skal gå raskere å installere og teste medfølger testsystemet One-Touch™ som gjør at styreenhetens funksjonalitet kan testes ved styreenheten eller leseren.

Test	Handling	Observasjon			
		Styreenhet		Leser	
Normal drift		 Grønn	Systemstatus: Den GRØNNE lysdioden blinker i normal hastighet.		
		 Grønn-Rød-Gul	Dørstatus: Alle lysdioder er av.		
One-Touch™ visningsmodus	Hold One-Touch™-knappen nede i mindre enn 2 sekunder. Presenter nøklene, trykk på RTE-bryterne og observer lysdiødene. Avsluttes automatisk etter 2 minutter.	 Grønn	Systemstatus GRØNN blinker i normal hastighet.	 Rød	
		 Grønn-Rød-Gul	Dørstatus: Grønn lyser – gyldig nøkkel er presentert for leseren.		
		 Grønn-Rød-Gul	Dørstatus: Grønn blinker – ugyldig nøkkel er presentert for leseren.		
		 Grønn-Rød-Gul	Dørstatus: Rød lyser – dør er åpen.		
		 Grønn-Rød-Gul	Dørstatus: Gul lyser – RTE-bryter er trykket inn.		
One-Touch™ aktiv modus	Hold nede One-Touch™-knappen i 2 til 4 sekunder.	 Grønn	Systemstatus: Den grønne lysdioden blinker raskere enn normalt.	 Grønn	Normal drift av lysdiodeendringene til leseren, dvs standard er rød som endres til grønn.
Test av leser og Forespørsel om utgang	Presenter en nøkkel for hver leser (låsen aktiveres).	 Grønn-Rød-Gul	Dørstatus: Den grønne lysdioden for døren blinker én gang for SIGA, to ganger for SIGB.	 Rød	Lysdioden til leseren blinker én gang for SIGA, to ganger for SIGB.
	Trykk på RTE-bryteren Forespørsel om utgang (låsen aktiveres).	 Grønn-Rød-Gul	Dørstatus: Den grønne lysdioden blinker tre ganger, og den gule lysdioden tennes.	 Rød	Lysdioden til leseren blinker tre ganger.
	Åpne dørkontakten.	 Grønn-Rød-Gul	Dørstatus: Den grønne lysdioden blinker fire ganger, og den røde er på.	 Rød	Lysdioden til leseren blinker fire ganger.
Test av ekstrareleer og låsereleer	Presenter en nøkkel for en leser, trykk på bryteren Forespørsel om utgang og åpne samtidig dørkontakten.				Det aktuelle ekstrareleet aktiveres.
	Ta bort koplingen til 0V for bryteren som gjelder sabotasje eller åpen krets.				Begge ekstrareleene aktiveres.
	Ta bort koplingen til 0V for nødoverstyring eller la kretsen for sabotasjebryteren være åpen.				Ekstrareleet aktiveres.
Test av sabotasje og overstyring	Bryt koplingen mellom TAMP og 0V på klemrekken Tamper & Override.				Ekstrareleet aktiveres men dørens releer påvirkes ikke.
	Bryt koplingen mellom OVRD og 0V på klemrekken Tamper & Override.				Både ekstrareleer og låsereleer aktiveres, døren åpnes og låsen fungerer.
Gå ut av One-Touch™ Aktiv Test-modus	Hold One-Touch™-knappen nede i mindre enn 2 sekunder. One-Touch™-testmodus blir automatisk tidsavbrutt etter 1 time, når den slås på eller slås av.	 Grønn	Systemstatus: GRØNN blinker med normal hastighet igjen.	 Rød	Lysdioden til leseren går tilbake til normal drift.

简介

本文档适用于熟悉 PAC 产品以及健康和安全生产注意事项目且经验丰富的工程师。

管理软件随附的文档和帮助文件中提供了关于软件安装和操作的附加信息。

系统上所有类似控制器的固件版本号应相同。

可能需要下载新控制器的固件，有关更多详细信息，请参阅帮助文件。

防拆和重写端子 (NC)

通电之前，请使用一根短电缆来链接：

- 防拆 (TAMP) 和 0V 端子。
- 重写 (OVERRIDE) 和 0V 端子。

如果需要，可以为终止寿命 (EOL) 操作配置重写。

RS-485 连接

如果使用屏蔽电缆，请将一个控制器上的屏蔽端连接到标有“SHIELD”的接地端。

链中只有第一个和最后一个控制器必须将 RS-485 变光开关设置为“IN”。

RS-485 LED	说明
红	控制器正在传输数据
绿	另一个控制器正在网络上传输数据

锁 EMF 抑制

所有锁都必须配备抑制大多数放电现象会产生的反电动势(“峰电压”)的手段(尤其是磁力锁)。

PAC 提供的所有阅读器和控制器都配有一个金属氧化物压敏电阻 (MOV)。

对于电流大于 1A 的情况，请使用**控制器**随附的**大 MOV**。

对于电流小于 1A 的情况，请使用**阅读器**随附的**小 MOV**。

MOV 可防止控制器遭到长期损坏。

只要可能，应将该装置安装到锁端子上。如果由于任何原因，无法访问锁端子，则可将 MOV 安装到锁输出端子上。

















锁继电器由与 **RELAY COM** 连接在一条线上的 **3A** 断路器提供保护。这些设置在移除重载时会复位；两个锁输出端子是独立的。

第 2-3 页上的接线图图例

1	RS-485 连接
2	变光开关设置 1. RS-485 端子 (IN 或 OUT, 默认 = OUT) 2. 阅读器电压选择器 (12/24V 或 5V, 默认 = 12/24V) 3. N/A 4. N/A
3	RS485 状态 LED
4	RS-232 状态 LED
5	门 1 LED
6	阅读器 +V 红 SIGA/SIGB 白 LED 棕 0V 黑 0V (门铃) 黄 0V(篡改/DC-门触点) 蓝
7	请求退出 (NO) RTE 蓝 0V 黑
8	
9	锁接线选项： • 故障保护—连接到 NC • 断电闭门—连接到 NO
10	—
11	序列号和条形码
12	One-Touch™ 按钮
13	系统状态 LED
14	电源接通
15	备用电池
16	12V/24V 有名无实电源供应器 橙 VIN 白 0V 粉 MSTAT 红 (电池)+ 黑 (电池)- 绿/黄 接地
17	PC RS-232 以太网连接
18	防拆开关 (NC)
19	
20	

One Touch™ 测试模式

为了加快安装与测试速度，我们提供了 One-Touch™ 测试模式。该模式支持在控制器或阅读器上测试控制器的功能。

测试	操作	观察			
		控制器	阅读器		
正常操作		 绿	系统状态: 以正常速率闪烁绿光。 门状态: 所有 LED 熄灭		
One-Touch™ 查看模式	按 One-Touch™ 按钮不超过 2 秒。显示钥匙，按 RTE 开关并观察 LED。2 分钟后自动退出。	 绿	系统状态: 以正常速度闪烁绿光。 门状态: 绿灯亮起，向阅读器出示了有效的钥匙。	 红	阅读器处于正常操作状态。
		 绿-红-黄	门状态: 绿灯闪烁，向阅读器出示了无效的钥匙。		
		 绿-红-黄	门状态: 红灯亮起，门打开。		
		 绿-红-黄	门状态: 黄灯亮起，已按下 RTE 开关。		
		 绿-红-黄			
One-Touch™ 活动模式	按住 One-Touch™ 按钮 2 到 4 秒。	 绿	系统状态: 比正常速率更快地闪烁绿光。	 绿	阅读器 LED 正常操作发生改变，例如，如果默认状态为红光，则变成绿光。
阅读器和请求退出测试	对每个阅读器显示一把钥匙(激活锁)。	 绿-红-黄	门状态: 为 SIGA 闪烁一次阅读器绿光，为 SIGB 闪烁两次。	 红	为 SIGA 闪烁一次阅读器 LED，为 SIGB 闪烁两次。
	按请求退出开关(激活锁)。	 绿-红-黄	门状态: 闪烁三次绿光，且亮起黄光。	 红	闪烁三次阅读器 LED。
	打开门触点。	 绿-红-黄	门状态: 闪烁四次绿光，且亮起红光。	 红	闪烁四次阅读器 LED。
辅助和锁继电器测试	为阅读器显示钥匙，按下请求退出开关并同时打开门触点。		激活适当的辅助继电器。		
	拆下防拆装置上的 0V 链路，并打开电路防拆开关。		激活两个辅助继电器。		
	拆下紧急改写装置上的 0V 链路，或者让电路防拆开关保持打开。		激活辅助继电器。		
防拆和改写测试	拆下防拆和改写端子块上 TAMP 与 0V 之间的链路。		激活辅助继电器，但门中继器不受影响。		
	拆下防拆和改写端子块上 OVRD 与 0V 之间的链路。		激活辅助继电器和锁继电器，门打开且锁正常操作。		
退出 One-Touch™ 活动测试模式	按 One-Touch™ 按钮不超过 2 秒。One-Touch™ 测试模式将在 1 小时后自动超时(打开或关闭电源)。	 绿	系统状态: 重新以正常速率闪烁绿光。	 红	阅读器 LED 恢复正常操作状态。

This page intentionally left blank

This page intentionally left blank



For enclosure installation details please go to • Per dettagli sull'installazione del contenitore andare su • Für Details zur Installation des Gehäuses gehen Sie bitte zu • Pour les détails d'installation de l'enceinte, veuillez consulter • Para los detalles de instalación de la caja, por favor vaya a • För information om installation i kapsling, gå till • Ga voor informatie over de installatie van de behuizing naar • For installasjonsdetaljer om innkapsling, gå til • 有关外壳安装的详细信息, 请转到

<https://pacgdx.com/products/pac-enclosures>

For full details visit • Per dettagli completi sul visitate • Für alle Einzelheiten besuchen Sie bitte • Pour de plus amples informations, consultez • Para obtener detalles completos visite • För komplett information, besök • Bezoek voor volledige gegevens • For mer informasjon, gå til • 有关完整详细信息, 请访问

<https://pacgdx.com/support/pac-product-literature>

Product Approvals Directives and Regulations • Approvazioni di prodotto Direttive e regolamenti
Produktzulassungen, Richtlinien und Vorschriften • Directives et règlements relatifs à l'approbation des produits
Directivas y normativas de las aprobaciones de productos • Direktiv och förordningar för produktgodkännanden
Richtlijnen en verordeningen productgoedkeuringen • Direktiver og forskrifter for produktgodkjenninger
产品批准指令和法规

EMC	2014/30/EU
LVD	2014/35/EU
RoHS	2011/65/EU
WEEE	2012/19/EU



This device complies with Part 15 of the FCC Rules. Operation is subject to the following two conditions: (1) this device may not cause harmful interference, and (2) this device must accept any interference received, including interference that may cause undesired operation.
This equipment has been tested and found to comply with the limits for a Class B digital device, pursuant to part 15 of the FCC Rules. These limits are designed to provide reasonable protection against harmful interference when the equipment is operated in a commercial environment. This equipment generates, uses, and can radiate radio frequency energy and, if not installed and used in accordance with the instruction manual, may cause harmful interference to radio communications. Operation of this equipment in a residential area is likely to cause harmful interference in which case the user will be required to correct the interference at his own expense.

IC This Class B digital apparatus complies with Canadian ICES-003. Cet appareil numérique de la classe B est conforme à la norme NMB-003 du Canada.



Waterside Court, 1 Crewe Rd, Manchester, M23 9BE — UK
Comelit Group S.p.A., Via Don Arrigoni n° 5, 24020 - Rovetta S. Lorenzo - BG — ITALY