



GDX Next Entrance Panel Expansion Unit

Quick Start Guide v1.0

Mar 2026

p/n: **EEUA** GDX Next Entrance Panel Expansion Unit with Access Control

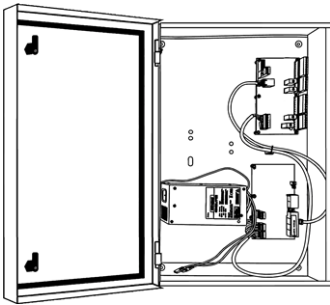

Technical Documentation

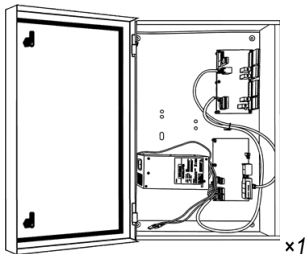

x1

EEUA



x2

Health & Safety



Failure to follow installation instructions may increase the risk of injury or death by electric shock, and may cause damage to hardware.

Intended use

This product is designed and manufactured for use in the creation of audio and video communication systems in residential and public buildings.

Installation and Safe usage

COMELIT-PAC products must be installed to:

- Meet the requirements of the country of installation's National Wiring Regulations (BS7671, IET National Wiring Regulations in the UK) and EN60950-1.
- Be carried out by suitably competent, qualified and experienced personnel.
- Comply with any local fire, health and safety regulations.
- Ensure hardware and controllers (e.g. entrance panels, readers, door controllers, etc.) are earthed.
- Ensure hardware is isolated at the power supply before commencing work on the unit(s).

Cabling

Control systems' cabling should be installed to reduce interference with other equipment and / or building environment.

- Do not run system cables alongside any heavy load switching cables.
- When you must run close to HV cables cross the cable at right angles every 1–2 m / 3–6 ft.
- To ensure safety, compliance, and ease of maintenance, we strongly recommend that all Extra Low Voltage (ELV) cabling be installed using dedicated sectioned cable trays or protective tubing.

For new installations

- PAC Secure Data Bus (SDB) requires a minimum of 4-core 0.5mm² cable.
- 4-core unscreened (2-wire 0.5mm² (gnd) + 2-wire 0.22mm²)
- Lock power connections must use 2-core 0.75 mm².

For retrofit options



For existing cabling, use cables with a cross-section suited to the current requirements and distances involved for data and lock connections.

Maintenance

- Any damaged or faulty products must be reported to COMELIT-PAC Technical Support.
- Any attempt to carry out repairs or modification to the electronic components or the physical product will void the product warranty.
- Check the product manual for any instructions regarding routine cleaning.
- Do not use alcohol or aggressive products for cleaning purposes.



If a sealed lead acid battery is installed, make a visual inspection twice a year for signs of damage or overcharging, to prevent possible fire risk.

ESD Precautions

The product contains static-sensitive devices and an earth grounding strap should be worn when handling the hardware.

Equipment Electrical Rating

All electrical equipment should have electrical ratings clearly stated on an identification label and in any documentation provided. Any applicable fuse ratings will also be specified within the documentation.

WEEE Directive and Product Disposal



At the end of its serviceable life this product should not be treated as household or general waste. It should be handed over to the applicable collection point for the recycling of electrical and electronic equipment or returned to the supplier for disposal.

Disclaimer

COMELIT-PAC Ltd. does not assume any responsibility for:

- Any purpose other than the intended use.
- Failure to observe the indications and warnings contained in this manual / instruction sheet.



COMELIT-PAC Ltd. reserves the right to change the information provided in this manual at any time and without prior notice.

1.0 Cable requirements

	Type	Distance
To Entrance Panels	Min. 4-core 0.5mm ² CAT5e (UTP)	100m max
To CCU	CAT5e (UTP)	
To readers	PAC Secure Data Bus (SDB) requires a min.of 4-core 0.5mm ² cable	
Lock power	must use 2-core 0.75 mm ²	
Network connection	CAT5e (UTP)	

2.0 Specifications

Enclosure Dimensions	403.5(w) × 606(l) mm	Cover
	399(w) × 598(l) × 96.8(d) mm	Rear
Weight	Approx. 11.5kg	
Operating temperature	−5 °C to +40 °C	
Humidity (RH max)	25% to 75% environmental class A1	

3.0 Installation – Enclosure

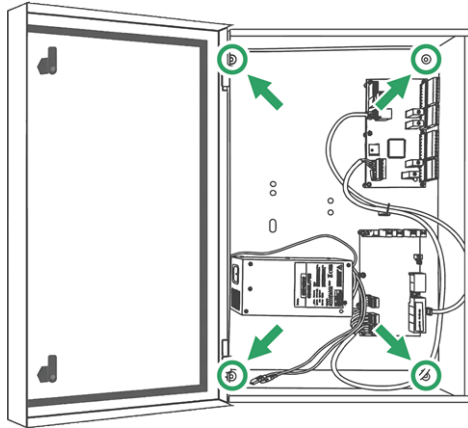

- Use appropriate fixings to secure the enclosure at the indicated positions.

! It is the responsibility of the competent and trained individual to observe appropriate precautions when handling, lifting or installing heavy loads that require wall mounting.

! Equipment should be installed in a safe location and be accessible for service personnel.

1. We recommend drilling additional cable openings BEFORE fixing to a wall.
2. For any additional holes required for cable entry:
 - i) Unlock the enclosure with the keys provided and remove the door.
 - ii) Remove the equipment mounting plate.
 - iii) Drill required holes and safely remove any remaining metal shards before fitting cable glands.



Use an appropriate cable gland suitable for the location of the enclosure.

3. Site the enclosure in a dry environment and mount vertically on a flat wall.
4. Use appropriate wall fixings to secure the enclosure to the wall.

Optional Battery Backup

The PSU comes complete with connections for a 7A/h battery including the charging circuit.

4.0 4 Door Controller layout

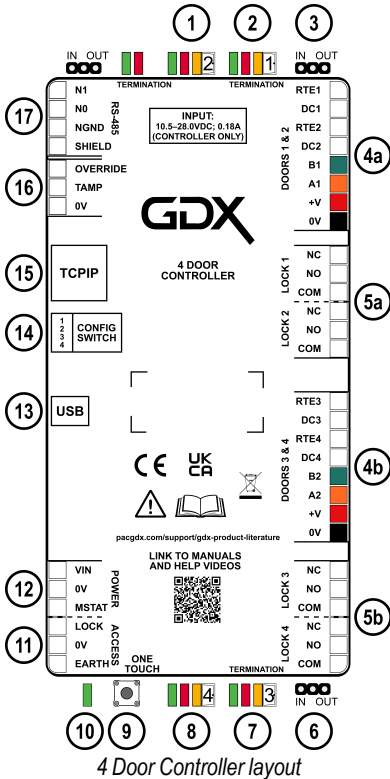

#	Detail
1, 2, 7, 8	Door status LEDs
3, 6	SDB channel terminators
4a, 4b	Door reader, RTE & DC connections
5a, 5b	Door lock connections
9	One-Touch™ button
10	System status LED
11	Lock supply output
12	PSU input
13	<i>Not used</i>
14	Configuration DIP switches
15	TCP/IP port
16	Override & Tamper connection
17	<i>Not used</i>

Door status LEDs (#1, 2, 7 & 8)

- The door channel number 1–4 is shown at the end.



During **standard operations** the following applies:

Type	Colour	Detail
LED	Green	Glows when reader LED is lit
DC	Red	N/A
RTE	Amber	Flashes for each discovered reader on the door channel E.g. 2× flashes = 2× readers

SDB (PAC Secure Data Bus) channel terminators (#3 & 6)

- Doors 1 & 2 jumper is located at **#3** (see 4 Door Controller layout)
- Doors 3 & 4 jumper is located at **#6** (see 4 Door Controller layout)
- Default position for jumpers is **OUT**.

! The FIRST and LAST devices in the PAC SDB network must be terminated as **IN**.

! If only 1× reader (Entrance Panel) is connected to the Door channel, set the **CONTROLLER JUMPER** to IN.

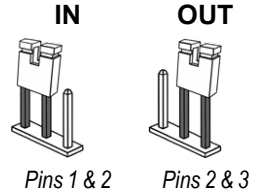

Door reader, RTE & DC connections (#4a & 4b)

Connection	Description	Devices
RTE #	Exit device (# is door number)	For exit devices
DC #	Door contact (# is door number)	For door contacts
B1 / B2 (green)	PAC SDB channel for Door 2 / 4	For Vandal readers
A1 / A2 (orange)	PAC SDB channel for Door 1 / 3	For Entrance Panel readers
+V (red)	12–24V power out	Power for readers
0V (black)	0V Ground	All devices

PAC SDB Ch0 (Doors 1 & 2)		PAC SDB Ch1 (Doors 3 & 4)	
Entrance Panel	Vandal reader†	Entrance Panel†	Vandal reader†
The primary Entrance Panel <u>must</u> be connected to “ Doors 1 & 2 ” in the CCU.		Only <u>ONE</u> Entrance Panel and/or <u>ONE</u> Vandal reader can be connected to “ Doors 3 & 4 ” in the CCU.	
† <i>2nd Entrance Panel and Vandal readers optional</i>			

Standalone Installation Configuration

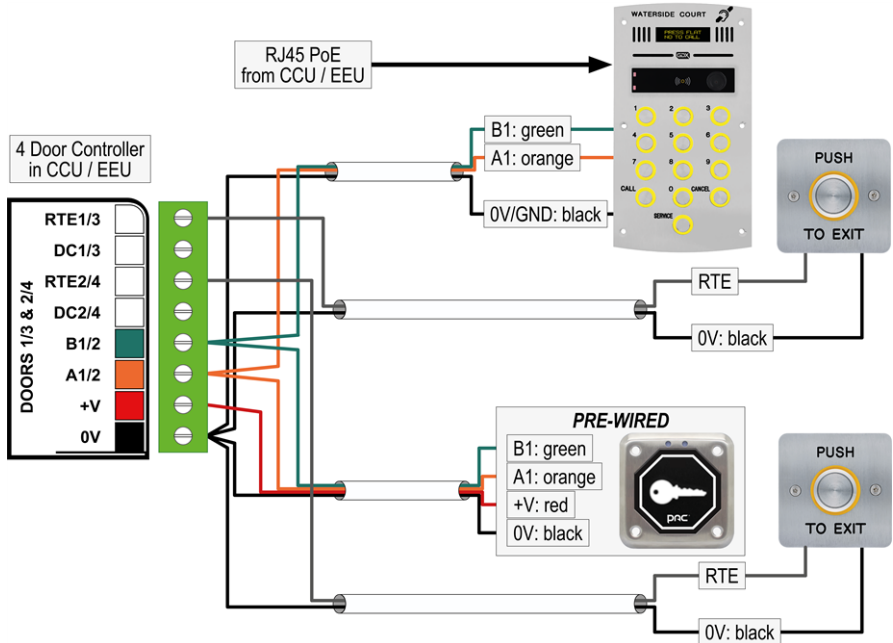

Door lock connections (#5a & 5b, 11)

3rd-party PSUs are supported and relays are rated to 5A @ 30V DC





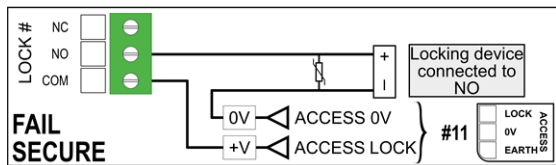
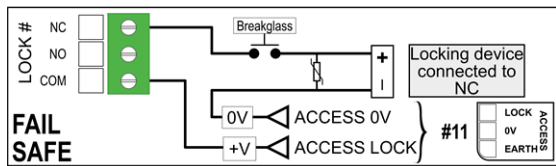































Lock wiring options

NC	Normally closed
NO	Normally open
COM	Common







One-Touch test button (#9)

- Enables testing the controller functionality to be tested at the controller or reader.

Test	Action	Observation			
		Controller		Reader	
Normal Operation	Door status: Each channel GREEN is solid	  Green	System status: GREEN flashes once per second	 Red	Access granted: solid GREEN for Lock release Access denied: RED to GREEN flashes 3 times
		    Green-red-amber	Door channel status: AMBER flashes for each reader discovered on the channel		
	Open circuit the Override and 0V terminals on the OVERRIDE / TAMP terminal block.	    Green-red-amber	All four locks activate.		
Enter One-Touch test mode	Hold down One-Touch button for 3-4 seconds	    Green-red-amber   Green	System status: GREEN flashes four times per second	 Green	LED changes to GREEN
Reader, RTE and Door Contact test	Present a key to each reader (the lock will activate).	    Green-red-amber	Door channel status: GREEN flashes once	 Red	RED flashes once
	Press the Request to Exit switch (the lock will activate)	    Green-red-amber	Door channel status: GREEN flashes three times and solid AMBER	 Red	RED flashes three times
	Open the door contact	    Green-red-amber	Door status: GREEN flashes four times and RED is on	 Red	RED flashes four times
Exit One-Touch test mode	Hold down the One-Touch button 3-4 secs. One-Touch Test mode times out after 1 hour.	  Green	System status: GREEN flashes once per second.	 Red	Reader LEDs revert back to red.

Configuration DIP switch settings (#14)

The configuration DIP switches enable different functions on the 4 Door Controller to be operated and configured.

				DIP switches are OFF .		↓ Push DIP switch DOWN to set to ON .
---	---	---	---	-------------------------------	---	--

 Push the DIP switch **DOWN** to set to **ON**.

Standalone Access Control

- i. Set DIP switch '1' to **ON**.
 - ii. DIP switches '2', '3' & '4' must be **OFF**.
- Access control is managed via the **primary Entrance Panel** (connected to **Door 1** on the GDX 4 Door Controller)

1. **ON**
2. **OFF**
3. **OFF**
4. **OFF**

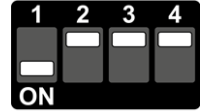

Discovery Mode

Request for all connected readers to provide their secure PAC SDB address to the controller.



“DISCOVERY MODE” is displayed on Primary Entrance Panel 1 and short rapid beeps emitted.

- i. Set DIP switch '2' to **ON**.
Request for all connected readers to provide their secure PAC SDB address to the controller.

1. **ON**
2. **ON**
3. **OFF**
4. **OFF**

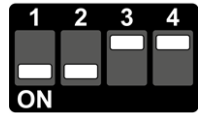

If DC (red) LED is lit, restart the DISCOVERY.

- ii. For each door with connected readers, the green LED will flash once for every reader detected on that channel.
E.g. 1× Entrance Panel + 1× Vandal Reader = 2× green flashes.



- iii. Set DIP switch '2' to **OFF** to return to standard operation.
- iv. Each Door channel LED (green) will stop flashing and the RTE (amber) will flash once for each reader discovered on that channel.



Editor Credential Programming Mode (Standalone mode only)



“PROGRAMMING MODE” is displayed on primary Entrance Panel 1 and short rapid beeps emitted.

- i. Set DIP switch '3' to **ON**.
- ii. DIP switch '2' must be **OFF**.

1. **ON**
2. **OFF**
3. **ON**
4. **OFF**

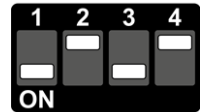

To add (or delete) Editor credentials



A maximum of 3 Editor credentials can be added.

- iii. Present the credential to the Entrance Panel reader.
The following messages may be displayed:

Message	Meaning
“TOKEN ADDED”	This credential was added as a Editor credential.
“TOKEN REMOVED”	This credential was already a Editor credential and was removed.
“PRESENT AGAIN”	No available slots for a new Editor credential.

- iv. Set DIP switch '3' to **OFF** to return to standard operation.

Reset Mode (Standalone mode only)



This will remove all Editor credentials from the system.



Residential credentials are **NOT** removed by RESET.

i. Set DIP switches '2', '3' & '4' to **OFF**.

1. **ON**
2. **OFF**
3. **OFF**
4. **OFF**

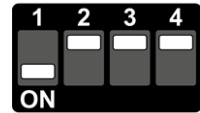

ii. Toggle DIP switch '4' **ON & OFF** 3 times within a 5-second period.

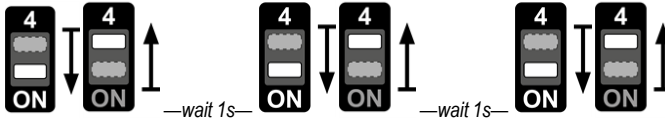

Performing a RESET when in One-Touch mode will **DELETE ALL** settings. This will require all readers and credentials to be discovered or added again.



The amber (RTE) LED will stop flashing. To confirm the reset is complete, present an Editor credential at any reader to check there is no response from the system.

To add (or delete) residents credentials



Only the primary Entrance Panel reader on Door 1 can be used to manage credentials.



A maximum of 2,000 residential credentials can be added.

- i. Present a **Editor** credential to the Entrance Panel reader on Door 1.
- ii. The display will show "DOOR OPEN", the reader will show green LEDs, and the sounder will trigger.
- iii. Within 3-seconds present the **same** Editor credential and the display will show "PROGRAMMING MODE".
- iv. Present residential credentials to the **primary** Entrance Panel 1 reader to add or delete them.

Message	Meaning
"TOKEN ADDED"	This credential was added as a Residential credential.
"TOKEN REMOVED"	This credential was already a Residential credential and was removed.

— Repeat step (iv) for all required credentials —

- v. To return the Entrance Panel to standard operation, present the **same** Editor credential, wait for 3-seconds and present the credential again.
- vi. The door will unlock, the reader will show a green LED, and the sounder will trigger.

TCP/IP Port (pre-wired)

The 4 Door controller TCP/IP port is connected to the EEU PCA "CTRL" port.



Tamper and Override Terminal (NC)

- TAMP and OVERRIDE are both Normally Closed circuits.

5.0 Default System Settings – Stanadalone Mode

Setting	Duration
Lock Release Time	5 seconds
Door Open Time	30 seconds
Door Forced Time	Immediate alert

Trade / Service Times		
Sunday	Monday – Friday	Saturday
8am to 10am	7am to 9am 5pm to 6pm	8am to 10am

Compliance



Do not discard this product along with other household waste. It must be collected and treated separately.

This page intentionally left blank

This page intentionally left blank

This page intentionally left blank

6.0 Troubleshooting

No power to EEU PCA / 4 Door Controller

- Check voltage from PSU is ~13.8V DC
- Check PSU LED status - refer to manufacturer label
- Verify POWER connections (VIN, 0V, MSTAT) are correctly terminated
- Ensure terminal blocks inserted fully into female terminator on EEU PCA

Reader Discovery issues

- Typically resolves in under 2 mins.
- Can take up to 5 minutes depending on cable distances and system parameters.
- Max. 100m distance from CCU to Reader.

Comms issues with Door Readers

- Ensure all connections are correctly terminated on 4 Door Controller
- Verify EEU PCA “CTRL” connection is fully inserted.
- Verify 4 Door Controller “TCPIP” connection is fully inserted.
- Check network connection from CCU to primary Entrance Panel is inserted correctly
- 2× readers on same Door channel, Controller jumper = **OUT**.
- 1× reader on Door channel, Controller jumper = **IN**.



Default position for 4 Door Controller jumper is **OUT**

- Door 1 & 2 jumper located at **#3**.
- Door 3 & 4 jumper located at **#6**.

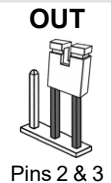
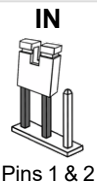

EEU connection from CCU

- Ensure RJ45 connection is inserted fully

COMELIT-PAC Ltd.

South Office

Unit 2b The Quad, Butterfield Business Park,
Luton, Beds. LU2 8EF

North Office

Waterside Court, 1 Crewe Rd, Manchester, M23 9BE

T: +44 (0)1707 377203

pacgdxsupport@comelit-pac.co.uk
pacgdxcustomerservice@comelit-pac.co.uk
pacgdxsales@comelit-pac.co.uk
trainingacademy@comelit-pac.co.uk

<https://www.pacgdx.com>