



GDX Next Entrance Panels DIGITAL

Quick Start Guide v1.0

Apr 2026

p/n: **DEP----** GDX Digital Entrance Panels (all variants)

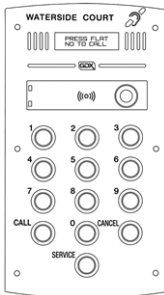

Technical Documentation

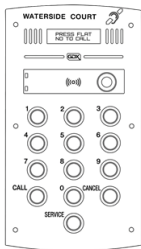

x1

DEP----
Digital Entrance Panel Example (all variants)



Backbox type depends on order



x1 or

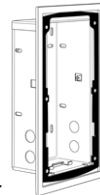

x1

Left: Compact backbox
Right: Mitre flush backbox

Health & Safety



Failure to follow installation instructions may increase the risk of injury or death by electric shock, and may cause damage to hardware.

Intended use

This product is designed and manufactured for use in the creation of audio and video communication systems in residential and public buildings.

Installation and Safe usage

COMELIT-PAC products must be installed to:

- Meet the requirements of the country of installation's National Wiring Regulations (BS7671, IET National Wiring Regulations in the UK) and EN60950-1.
- Be carried out by suitably competent, qualified and experienced personnel.
- Comply with any local fire, health and safety regulations.
- Ensure hardware and controllers (e.g. entrance panels, readers, door controllers, etc.) are earthed.

Cabling

Control systems' cabling should be installed to reduce interference with other equipment and / or building environment.

- Do not run system cables alongside any heavy load switching cables.
- When you must run close to HV cables cross the cable at right angles every 1–2 m / 3–6 ft.
- To ensure safety, compliance, and ease of maintenance, we strongly recommend that all Extra Low Voltage (ELV) cabling be installed using dedicated sectioned cable trays or protective tubing.

For new installations

- PAC Secure Data Bus (SDB) requires a minimum of 4-core 0.5mm² cable.
- 4-core unscreened (2-wire 0.5mm² (gnd) + 2-wire 0.22mm²)

For retrofit options



For existing cabling, use cables with a cross-section suited to the current requirements and distances involved for data connections.

Maintenance

- Any damaged or faulty products must be reported to COMELIT-PAC Technical Support.
- Any attempt to carry out repairs or modification to the electronic components or the physical product will void the product warranty.
- Check the product manual for any instructions regarding routine cleaning.
- Do not use alcohol or aggressive products for cleaning purposes.

RFID Devices

RFID technology is now widely used in a number of industries, it is possible that interaction between your credential and other devices in the vicinity may cause incorrect operation or recognition. Should you suspect that you have experienced such a problem, ensure the interfering device is out of range. **This only applies if any RFID devices have been fitted.**

Equipment Electrical Rating

All electrical equipment should have electrical ratings clearly stated on an identification label and in any documentation provided. Any applicable fuse ratings will also be specified within the documentation.

WEEE Directive and Product Disposal



At the end of its serviceable life this product should not be treated as household or general waste. It should be handed over to the applicable collection point for the recycling of electrical and electronic equipment or returned to the supplier for disposal.

Disclaimer

COMELIT-PAC Ltd. does not assume any responsibility for:

- Any purpose other than the intended use.
- Failure to observe the indications and warnings contained in this manual / instruction sheet.



COMELIT-PAC Ltd. reserves the right to change the information provided in this manual at any time and without prior notice.

Compliance



Do not discard this product along with other household waste. It must be collected and treated separately.

1.0 Entrance Face Plate

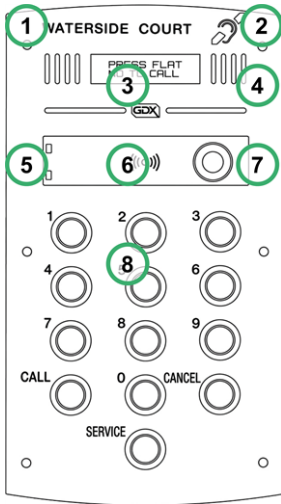

#	Description
1	Engraving (if present)
2	Hard of Hearing by default
3	Message display screen
4	Speaker
5	Reader LEDs
6	RFID Proximity reader
7	Camera (optional)
8	Button matrix

2.0 Installation of Hardware



It is the responsibility of the competent and trained individual to observe appropriate precautions when handling, lifting or installing heavy loads that require wall mounting.



Please order ACYEQ-007 Power Bit Monodrive 5 for M4 screws from COMELIT-PAC.

2.1 Entrance Panel Variants



GDX Next Entrance Panel backboxes have similar dimensions as older GDX5 Entrance Panels.

Type	GDX Next	GDX5
Compact	<ul style="list-style-type: none"> 255 (h) × 123 (w) mm Depth approx. 65 mm 	Height and width are identical. Check depth , some older versions are approx. 55 mm
Mitre	<ul style="list-style-type: none"> 255 (h) × 123 (w) mm Depth approx. 75 mm 	All dimensions are <u>identical</u>

2.2 Product Mounting

The entrance panel is supplied with a standard backbox. If there is already a backbox fitted in the building please dispose of the surplus backbox as per the instructions in the WEEE Directive and Product Disposal.

Backbox types

- **Mitre** – has a bezel, 75 mm deep and panel plate is inset.
- **Compact** – no bezel, 55 mm or 65 mm deep and panel plate is fixed directly to the front.

Backbox installation (if required)



Only follow these steps if a backbox has not been fitted.

1. Remove the panel from the packaging and release the six security screws fixing the faceplate to the backbox.
2. Remove the front face plate and disconnect the PCB connectors from the rear of the face plate noting the correct order.

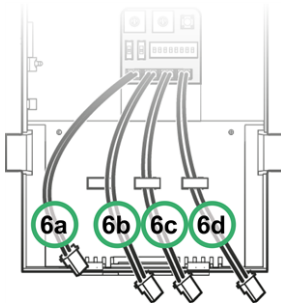

Connectors for button PCBs

- 6a connects to the 1st column
- 6b connects to the 2nd column
- 6c connects to the 3rd column
- 6d connects to the 4th column

3. Cut out a hole for the backbox 'inside' the fixing holes.



Recommended optimal mounting height 1400mm – CENTRE OF CAMERA



Recommended mounting height 1150-1200mm – CENTRE OF CAMERA

4. Dimensions for backbox are 255 (h) × 123 (w) mm.
 - i) Hole depth is determined by the model – Mitre or Compact.
 - ii) Use the cable entry knock-outs provided in the backbox.



In metal backboxes use rubber grommets (not supplied) in the knock-outs.

5. Secure the backbox with appropriate fixings for the mounting surface.
6. Place chassis into the backbox at a **45° angle** and line up the chassis slot with the backbox bracket.



Chassis slot (bottom of chassis frame)

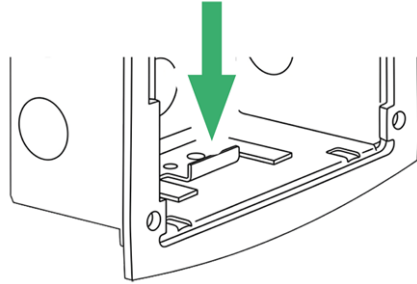

Backbox bracket

7. Reconnect all PCB connectors, starting with 6a plugged into the first column of buttons on the face plate.

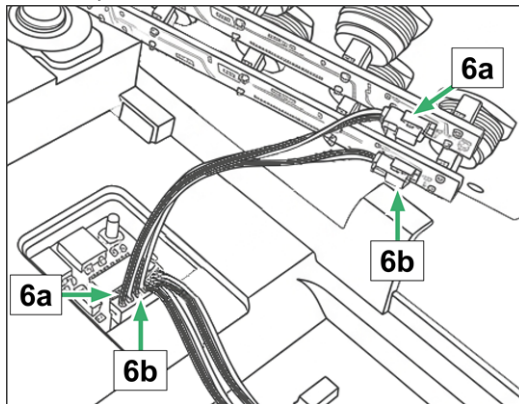

8. Affix the faceplate to the backbox.

For reference only and **NOT** to scale.

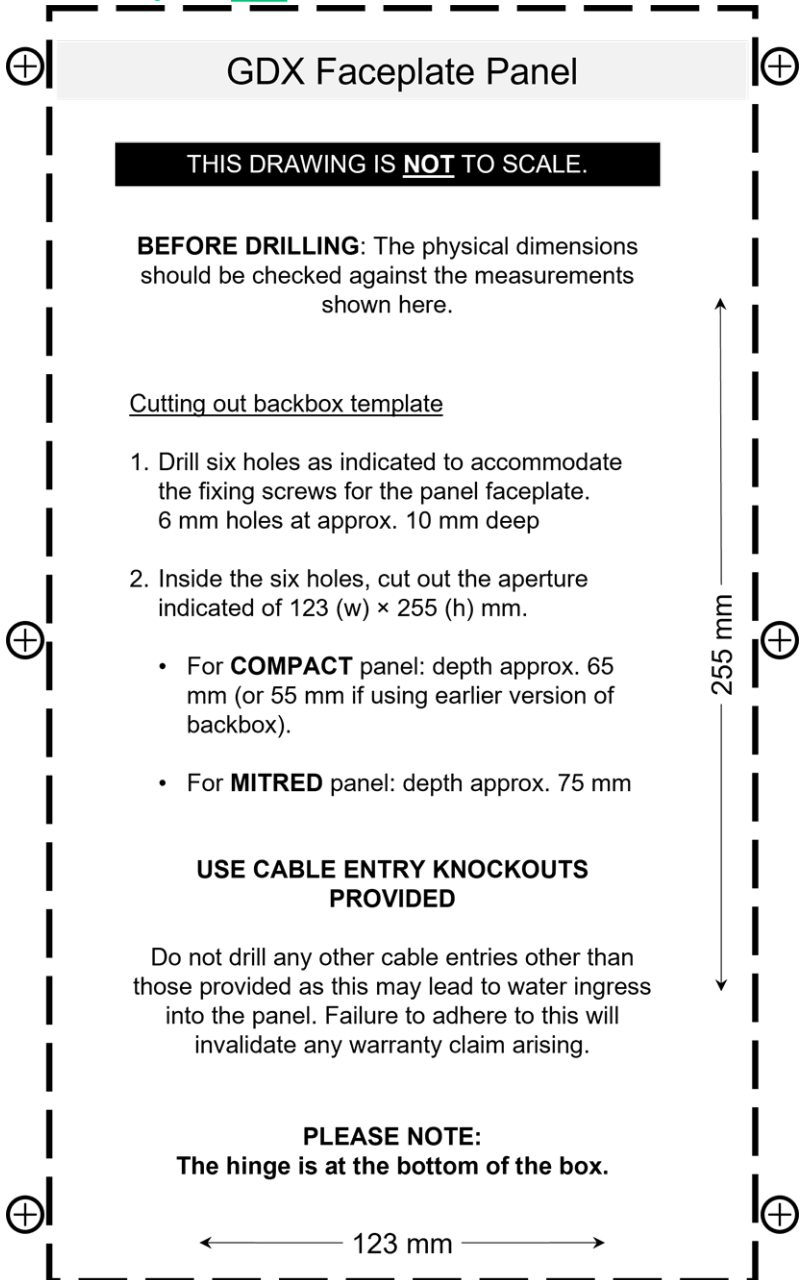

2.3 Connection to CCU / EEU

A 4 Door Controller is included as part of the GDX Next with Access Control solution and the following must be observed when installing connections for the Entrance Panel.

	Type	Distance
To CCU or EEU	Min. 4-core 0.5mm ² <i>Only 3 are used for 0V, PAC SDB A and B</i>	100m max
	CAT5e PoE (UTP) network cable	

2.3.1 Rear Connections on Entrance Panel

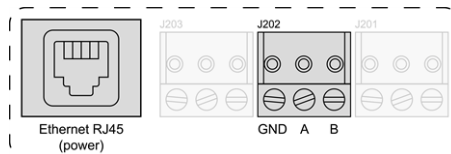

- **Ethernet RJ45** connects to **EP1** or **EP2** in CCU or EEU enclosure.
- **GND, A** and **B** connects to **0V, A1 / A2** and **B1 / B2** in CCU / EEU (depending on PAC SDB channel.)



If the Entrance Panel is the only reader installed on the PAC SDB channel, terminate the PAC SDB channel on the 4 Door Controller = IN.

2.3.2 Door readers, RTE & DC connections (CCU / EEU)

Connection	Description	Devices
RTE #	Exit device (# is door number)	For exit devices
DC #	Door contact (# is door number)	For door contacts
B1 / B2 (green)	PAC SDB channel for Door 2 / 4	For ALL readers
A1 / A2 (orange)	PAC SDB channel for Door 1 / 3	
+V (red)	12–24V power out	Power for Vandal readers
0V (black)	0V Ground	ALL devices

2.3.3 Default Button Mapping

Entrance Panel layout examples

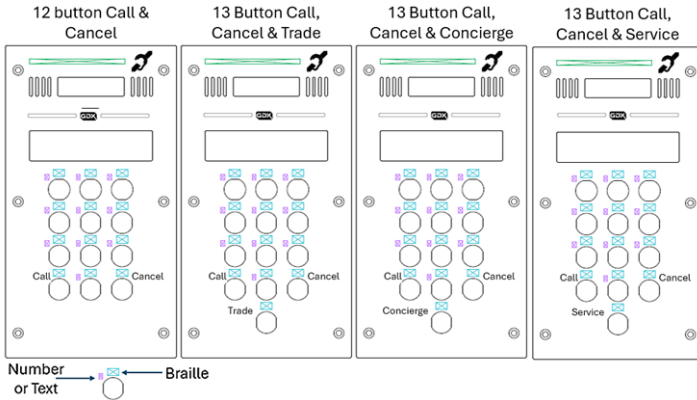

2.3.4 Entrance Panel and Vandal reader support

The GDx Next Standalone solution will support:

- Min. ONE Entrance Panel connected to the CCU.
- Max. TWO Entrance Panels and TWO Vandal readers connected to the CCU.

PAC SDB Ch0 (Doors 1 & 2)		PAC SDB Ch1 (Doors 3 & 4)	
Entrance Panel	Vandal reader†	Entrance Panel†	Vandal reader†
The primary Entrance Panel <u>must</u> be connected to “Doors 1 & 2” in the CCU.		Only <u>ONE</u> Entrance Panel and/or <u>ONE</u> Vandal reader can be connected to “Doors 3 & 4” in the CCU.	
† 2 nd Entrance Panel and Vandal readers optional			

2.3.5 Standalone Installation Configuration

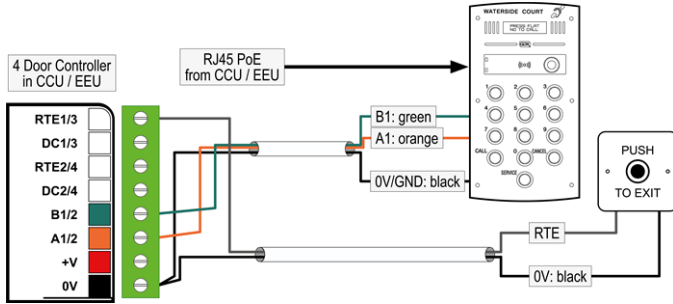















The 4 Door Controller must 'Discover' all readers when installation is complete.

3.0 Default System Settings – Standalone Mode

Setting	Duration
Lock Release Time	5 seconds
Door Open Time	30 seconds
Door Forced Time	Immediate alert

Trade / Service Times		
Sunday	Monday – Friday	Saturday
8am to 10am	7am to 9am, 5pm to 6pm	8am to 10am

4.0 Entrance Panel messages

Message displayed	Reason
INITIALISING - PLEASE WAIT	At system power up no message displayed for approx. 60 sec . After this period, the initialising message is displayed for approx. 60 sec .
PRESS FLAT NO. TO CALL	Default message displayed when Entrance Panel is idle
CALLING FLAT ###	Call initiated on a Digital panel  "Call forwarded, speak after the beep" and  double tone played
CALL ANSWERED	Call is answered in the flat (call time 30 sec limit)
DOOR OPEN <i>Door contact required</i>	Door unlocked by flat, valid credential presented or RTE  "You can enter"
CALL COMPLETE	Call ended / call time expired (30 sec limit)  Double tone played at end of call
CALL NOT ANSWERED	No response from flat or concierge  "User not available"
NOT RECOGNISED	 x4 rapid tones played
BUSY	Flat called is on another call  "User is busy please wait" and rapid engaged tones  x4 played
ACCESS DENIED	Invalid credential presented  "Access denied"
ACCESS DENIED - TRADE TIME	Trade / Service button pressed outside of Trade time profile  "Access denied"
ALERT - DOOR FORCED	Door opened by unauthorised method Immediate alert followed by 30 sec repeats until cleared  x4 tones played
ALERT - DOOR LEFT OPEN	Door open time exceeded (30 sec default) Alert repeats every 30 seconds until cleared  x4 tones played
ALERT - FIRE SWITCH ACTIVE	Door opened via Fire switch override Immediate alert followed by 30 sec repeats until cleared  x4 tones played
ALERT - RTE	RTE button is being held Immediate alert followed by 30 sec repeats until cleared  x4 tones played

Advanced Settings and Information

i) Entrance Panel - internal front



For standard installations, only the configuration switches may be required to adjust volume or change button mapping.

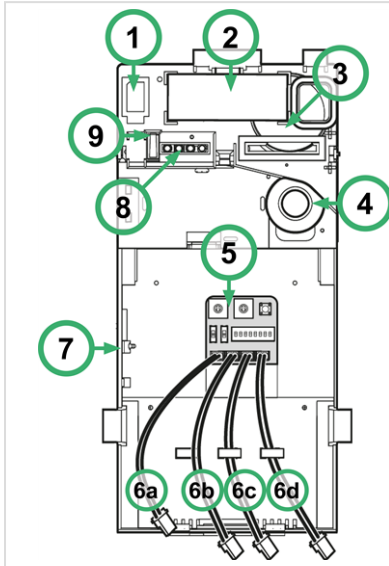

#	Description (from top-left clockwise)
1	Microphone
2	LCD display screen
3	Speaker
4	Camera
5	Configuration switches
6	Connectors for button PCBs <ul style="list-style-type: none"> • 6a connects to the 1st column • 6b connects to the 2nd column • 6c connects to the 3rd column • 6d connects to the 4th column
7	Earthing point
8	Light for night time camera image
9	Tamper

ii) Volume Adjustment



Configuration switches are located on the front chassis of the Entrance Panel.

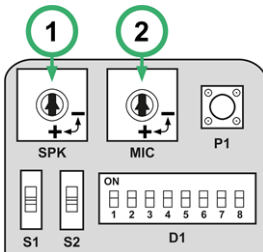

#	Description
1	SPK Front panel speaker vol. Turn clockwise to increase.
2	MIC Front panel microphone volume. Turn clockwise to increase.

iii) Credential Management - Standalone Mode only



Credential management tasks are performed at the primary Entrance Panel in Standalone mode.

- i. In the CCU, set the 4 Door Controller DIP switch '3' to **ON**.
- ii. DIP switch '2' must be **OFF**.

- 1. **ON**
- 2. **OFF**
- 3. **ON**
- 4. **OFF**



“PROGRAMMING MODE” is displayed on the primary Entrance Panel and short rapid beeps emitted.

Add (or delete) Editor credentials



A maximum of 3 Editor credentials can be added.

- iii. Present the credential to the **primary** Entrance Panel reader and the following messages may be displayed:

Message	Meaning
“TOKEN ADDED”	This credential was added as an Editor credential.
“TOKEN REMOVED”	This credential was already an Editor credential and was removed.
“PRESENT AGAIN”	No available slots for a new Editor credential.

- iv. Set DIP switch '3' to **OFF** to return to standard operation.

Add (or delete) residents credentials



Only the primary Entrance Panel reader can be used to manage credentials.



A maximum of 2,000 residential credentials can be added.

- i. Present an **Editor** credential to the **primary** Entrance Panel reader.
- ii. The display will show “DOOR OPEN”, the reader will show green LEDs, and the sounder will trigger.
- iii. Within 3-seconds present the **same** Editor credential and the display will show “PROGRAMMING MODE”.
- iv. Present residential credentials to the **primary** Entrance Panel reader to add or delete them.

Message	Meaning
“TOKEN ADDED”	This credential was added as a residential credential.
“TOKEN REMOVED”	This credential was already a residential credential and was removed.

— Repeat step (iv) for all required credentials —

- v. To return the Entrance Panel to standard operation, present the **same** Editor credential, wait for 3-seconds and present the credential again.
- vi. The door will unlock, the reader will show a green LED, and the sounder will trigger.

Troubleshooting

No power to the Entrance Panel

- Check the RJ45 PoE lead is plugged in on the rear of the Entrance Panel.
- Check the RJ45 PoE lead is plugged into EP1 / EP2 in the CCU / EEU.
- The initial power up will last 60 secs with **no display messages**.

Button does not call the flat / Handset does not ring in the flat

- Check the handset is not set to Privacy mode.
- Check the flat handset is addressed correctly.
- Check the button PCB connector is plugged in at the rear of the face plate.

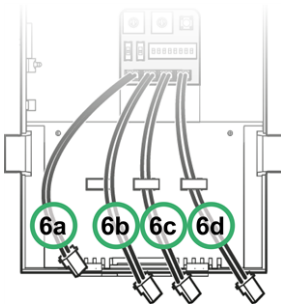

- 6a connects to the 1st column.
- 6b connects to the 2nd column.
- 6d connects to the 4th column.
- 6c connects to the 3rd column.

Entrance Panel displays:

- INITIALISING – PLEASE WAIT: Part of the system power up process and can take up to 60 secs.
- ACCESS DENIED: Add the credential via the primary Entrance Panel.
- NOT RECOGNISED: Check the button mapping and handset addressing.
- BUSY: The flat is already on a call.
- PROGRAMMING MODE:
 - **Dip switch 3** on the 4 Door Controller is ON (DOWN)
Move the switch **UP**.
 - Present a valid **Editor credential** TWO times to cancel residential credential management mode.

Entrance Panel volume issues:

- Caller audio is not loud enough for resident:
 - Adjust MIC in Entrance Panel, see *Advanced settings*.
- Resident too quiet at Entrance Panel:
 - Adjust SPK in Entrance Panel, see *Advanced settings*.
 - Adjust MIC setting on resident handset.

Comms issues with Door Readers

- Ensure all connections are correctly terminated on 4 Door Controller in CCU / EEU.
- Verify CCU PCA “CTRL” connection is fully inserted.
- Verify 4 Door Controller “TCPIP” connection in CCU / EEU is fully inserted.
- Check network connection from CCU to primary Entrance Panel is inserted correctly.
- 2× readers on same Door channel → Controller jumper = **OUT**.
- 1× reader on Door channel → Controller jumper = **IN**.



Default position for 4 Door Controller jumper is **OUT**

- Door 1 & 2 jumper at **top edge** of controller.
- Door 3 & 4 jumper at **bottom edge** of controller.

IN

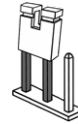

Pins 1 & 2

OUT

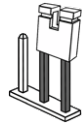

Pins 2 & 3

COMELIT-PAC Ltd.

South Office

Unit 2b The Quad, Butterfield Business Park,
Luton, Beds. LU2 8EF

North Office

Waterside Court, 1 Crewe Rd, Manchester, M23 9BE

T: +44 (0)1707 377203

pacgdxsupport@comelit-pac.co.uk
pacgdxcustomerservice@comelit-pac.co.uk
pacgdxsales@comelit-pac.co.uk
trainingacademy@comelit-pac.co.uk

<https://www.pacgdx.com>